

**Hjälpmedel:** Ett A4-ark (båda sidor) med studentens egna anteckningar på valfritt sätt: handskrivet eller datorutskrift; text eller diagram; stor eller liten textstorlek, ... Det behöver *inte* lämnas in.

Tentan har 5 tal i två sektioner: 3 i sektion A (12p), och 2 i sektion B (10p). Godkänd kräver:

$$\frac{\max(a, a_k)}{A} \geq 40\% \quad \& \quad \frac{b}{B} \geq 40\% \quad \& \quad \frac{\max(a, a_k) + b + p}{A + B} \geq 50\%$$

där  $A=12$  och  $B=10$  är de maximala möjliga poängen från sektionerna A och B,  $a$  och  $b$  är poängen man fick i dessa respektive sektioner i tentan,  $a_k$  är poängen man fick från KS1 vilken motsvarar tentans sektion A, och  $p$  är bonuspoäng från hemuppgifterna, motsvarande högst 5% (1,1p); funktionen  $\max()$  tar den högre av sina argument.

Betyget räknas från summan över båda sektioner, igen med bästa av sektion A och KS1,  $\frac{\max(a, a_k) + b + p}{A + B}$ . Betygsgränserna är 50% (E), 60% (D), 70% (C), 80% (B), 90% (A).

Om inte annan information anges i ett tal, ska: komponenter antas vara idéala; angivna värden av komponenter (t.ex.  $R$  för ett motstånd,  $U$  för en spänningskälla,  $k$  för en beroende källa) antas vara **kända** storheter; och andra markerade storheter (t.ex. strömmen markerad i ett motstånd eller en spänningskälla) antas vara **okända** storheter.

Lösningar ska uttryckas i kända storheter, och förenklas. Var tydlig med diagram och definitioner.

**Dela tiden** mellan talen — senare deltal brukar vara svårare att tjäna poäng på ... fastna inte!

**Kontrollera** svarens rimlighet genom t.ex. dimensionskoll eller alternativ lösningsmetod.

Lycka till!

Nathaniel Taylor (073 949 8572)

## Del A. Likström

1) [4p] Bestäm följande storheter:

- [1p] Effekten absorberad av  $R_1$ .
- [1p] Effekten absorberad av källan  $I_1$ .
- [2p] Strömmen  $i_x$ .

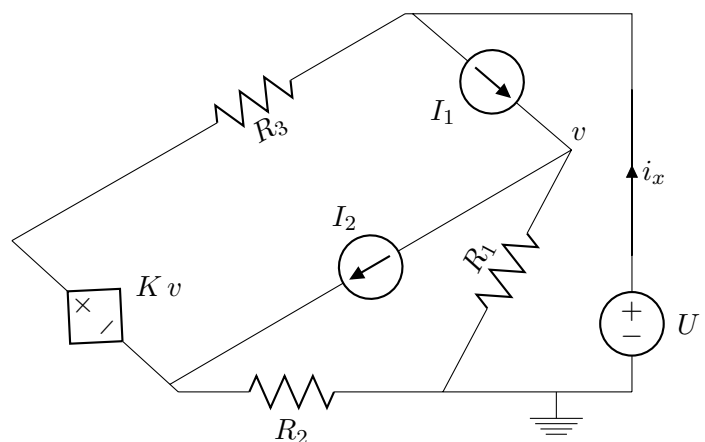

2) [4p]

Använd nodanalys för att skriva ekvationer som skulle kunna lösas för att få ut de markerade potentialerna  $v_1, v_2, v_3, v_4, v_5$ .

Du behöver bara visa att du kan översätta från kretsen till ekvationerna: du *måste inte* lösa eller förenkla ekvationerna.

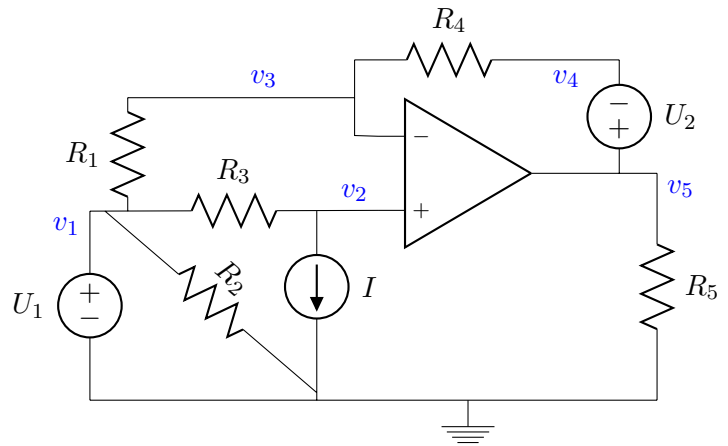

3) [4p]

a) [2p] Bestäm Theveninekvivalenten, med avseende på polerna a-b, när brytaren är öppen ( $t < 0$ ).

b) [2p] Bestäm Nortonekvivalenten, med avseende på polerna a-b, när brytaren är stängd ( $t > 0$ ).

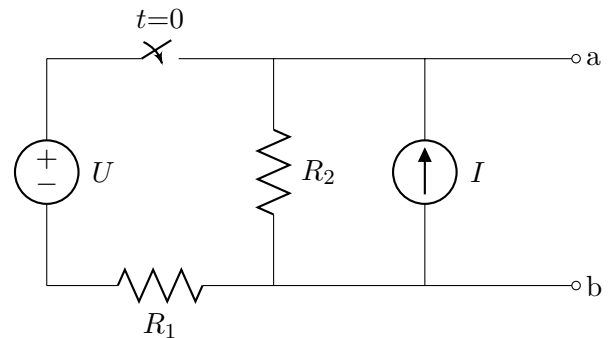

## Del B. Transient

4) [5p]

Bestäm följande storheter, vid de angivna tiderna.

a) [1p]  $t = 0^-$   
Effekten försörjd från källan  $I$ .

b) [2p]  $t = 0^+$   
Energien lagrad i  $C_1$ .  
Effekten absorberad av  $R_3$ .

c) [2p]  $t \rightarrow \infty$   
Effekten absorberad av  $R_1$ .  
Energien lagrad i  $L_2$ .

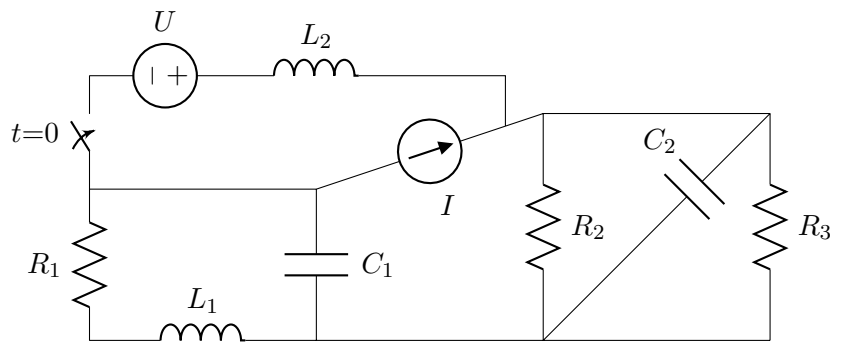

5) [5p]

Nu analyseras en krets som består av en kondensator  $C$  kopplad mellan polerna a-b av kretsen som visas i tal 3 (ovan). Kondensatorn var kopplad länge innan  $t = 0$ , så jämvikt kan antas innan brytaren stängs.

Bestäm tidsfunktionen som beskriver strömmen genom kondensatorn, från pol a till b, vid tider efter att brytaren stängs ( $t > 0$ ).

**Slut.** Men *slösa inte eventuell återstående tid: kolla och dubbelkolla svaren.*

## Solutions (EI1110 TEN1 HT16, 2016-12-19)

### Q1.

a)  $P_{R_1, \text{in}} = (I_1 - I_2)^2 R_1$

KCL at node above  $R_1$  gives  $I_1 - I_2$  as the current down through  $R_1$ . Note that  $(I_1 - I_2)^2 = (I_2 - I_1)^2$ .

b)  $P_{I_1, \text{in}} = I_1 (U - I_1 R_1 + I_2 R_1)$

Power absorbed by the source is the product of its current  $I_1$  and the voltage across it (with positive reference direction where the current is marked as going in). The voltage is found by KVL, around the loop including  $R_1$  and  $U$ . The voltage across  $R_2$  is known by Ohm's law and the known current from part 'a'.

c) [ $i_x$ : see the end of the solution, below.]

This is a lot harder than the previous ones. If we can find the current in  $R_3$ , or in  $R_2$ , then KCL at the top or bottom node will give a solution for  $i_x$ , as the other currents at those nodes are already defined by the current sources. As described in the earlier solutions, the voltage across  $R_1$  is  $v = R_1(I_1 - I_2)$ , so the voltage of the dependent voltage source  $Kv$  is fixed as  $KR_1(I_1 - I_2)$ .

To use nodal analysis (with supernode and simplification methods), let us define the potential at the left of  $R_2$  as  $v_x$ . Taking KCL for the supernode comprising both sides of the dependent source  $Kv$ ,

$$\begin{aligned} \frac{v_x}{R_2} - I_2 + \frac{v_x + KR_1(I_1 - I_2) - U}{R_3} &= 0 \\ v_x \left( \frac{1}{R_2} + \frac{1}{R_3} \right) &= v_x \frac{R_2 + R_3}{R_2 R_3} = I_2 + \frac{U}{R_3} - \frac{KR_1(I_1 - I_2)}{R_3} \\ v_x &= \frac{\left( I_2 + \frac{U}{R_3} - \frac{KR_1(I_1 - I_2)}{R_3} \right) R_2 R_3}{R_2 + R_3} = \frac{(I_2 R_3 + U - KR_1(I_1 - I_2)) R_2}{R_2 + R_3} \end{aligned}$$

By KCL in the bottom node, noting that the current downwards in  $R_1$  is  $I_1 - I_2$ ,

$$i_x = \frac{v_x}{R_2} + I_1 - I_2.$$

Inserting the earlier solution of  $v_x$ ,

$$i_x = \frac{I_2 R_3 + U - KR_1(I_1 - I_2)}{R_2 + R_3} + I_1 - I_2.$$

which might (?) look more appealing if arranged as

$$i_x = \frac{U + I_1(R_2 + R_3 - KR_1) + I_2(KR_1 - R_2)}{R_2 + R_3}.$$

### Q2.

#### Example Method i) Extended nodal analysis ("the simple way to write")

Let's define the unknown currents in the voltage sources:  $i_\alpha$  and  $i_\beta$  into the + terminals of sources  $U_1$  and  $U_2$  respectively; and  $i_\gamma$  into the output terminal of the opamp. (Yes – don't forget the opamp output, if planning to write KCL at that node!)

Write KCL (let's take outgoing currents) at all nodes except the earth node:

$$\text{KCL(1)} : 0 = \frac{v_1 - v_3}{R_1} + \frac{v_1 - v_2}{R_3} + \frac{v_1}{R_2} + i_\alpha \quad (1)$$

$$\text{KCL(2)} : 0 = \frac{v_2 - v_1}{R_3} + I \quad (2)$$

$$\text{KCL(3)} : 0 = \frac{v_3 - v_1}{R_1} + \frac{v_3 - v_4}{R_4} \quad (3)$$

$$\text{KCL(4)} : 0 = \frac{v_4 - v_3}{R_4} - i_\beta \quad (4)$$

$$\text{KCL(5)} : 0 = \frac{v_5}{R_5} + i_\beta + i_o \quad (5)$$

Each voltage source relates a pair of node potentials. The simple independent sources are easy.

$$v_1 = U_1 \quad (6)$$

$$v_5 - v_4 = U_2 \quad (7)$$

The opamp gives us the knowledge that  $v_+ = v_-$  (i.e.  $v_3 = v_3$  in this circuit) on the assumption of negative feedback (which we see through  $R_4$ ) and an ideal opamp (which we assume because everything's ideal unless claimed otherwise!).

$$v_2 = v_3 \quad (8)$$

THE ABOVE EQUATION-SYSTEM IS SUFFICIENT FOR A SOLUTION.

### Example Method ii) Simplifications (including supernodes) to reduce the equations

There are three voltage-sources in the circuit: two independent sources, and the opamp (which we treat as a dependent voltage source between earth and output). We note that  $U_1$  and the opamp each have one side connected to the earth node (the opamp's connection is hidden in the diagram), and  $U_2$  connects to the opamp output.

Thus, we can treat nodes 1, 5 and 4 as one supernode, which is an earth supernode: KCL is only needed on nodes 2 and 3. One potential in the supernode is immediately determined:  $v_1 = U_1$ . The other parts have an unknown: source  $U_2$  gives the equation  $v_4 = v_5 - U_2$ , but the opamp's output voltage will be determined later by solving the equation system with the extra equation of  $v_+ = v_-$ . So we'll choose the node 4 or 5 potential (let's take  $v_5$ ) as a further unknown in the equations. Using only these three unknowns ( $v_2, v_3, v_5$ ), substituting other ones with known quantities, KCL gives:

$$\text{KCL(2)} : 0 = \frac{v_2 - U_1}{R_3} + I \quad (1)$$

$$\text{KCL(3)} : 0 = \frac{v_3 - U_1}{R_1} + \frac{v_3 - v_5 + U_2}{R_4} \quad (2)$$

The extra information due to the opamp is essential in order to let the three unknowns in the above two equations be solved:

$$v_2 = v_3 \quad (3)$$

The above three equations are sufficient to find the three unknowns ( $v_2, v_3, v_5$ ) but in order to "solve for all 5 potentials" we should clearly show the other two equations we've already mentioned in the text:

$$v_1 = U_1 \quad (4)$$

$$v_4 = v_5 - U_2 \quad (5)$$

**Q3.**

Note that the switch is the only time-dependent thing in this circuit: there is no capacitor or inductor that slows the changes. So, each quantity in the circuit has a constant value over all time  $t < 0$ , and a (possibly different) constant value over all time  $t > 0$ . The subquestions 'a)' and 'b)' can be seen as being about equivalents of two different circuits, formed by having the switch open or closed.

a) At  $t < 0$ , the circuit (left) and its Thevenin equivalent (right) are:

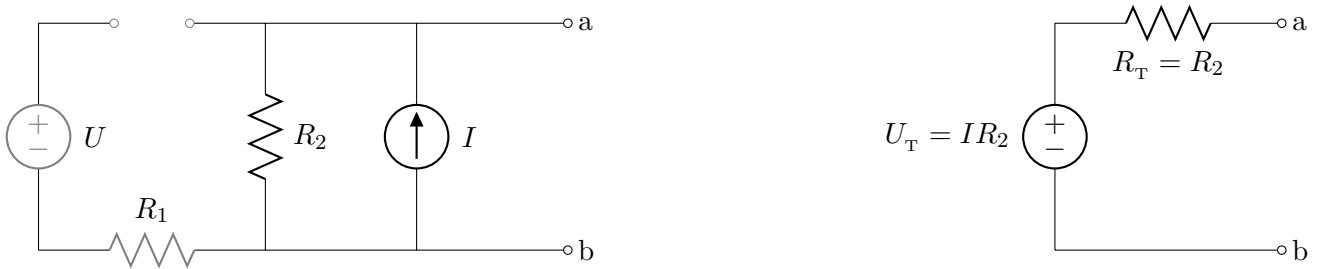

b) At  $t > 0$ , the circuit (left) its and Norton equivalent (right) are:

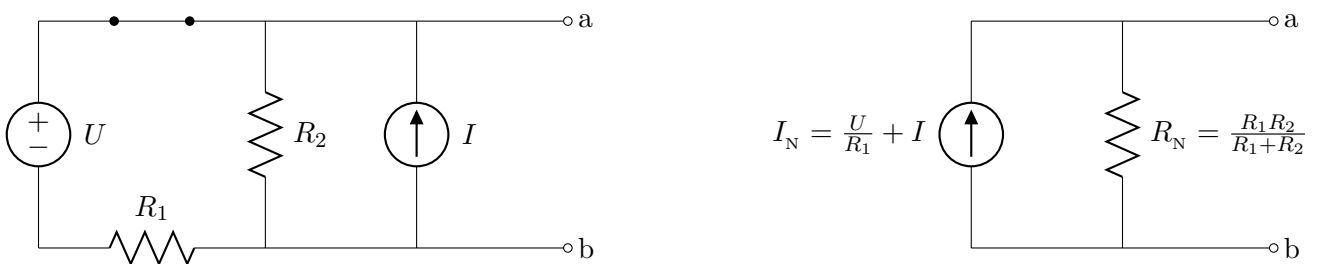

The above results can be seen by considering open-circuit conditions (in part a) or short-circuit conditions (in part b) to obtain the equivalent source values  $U_T$  and  $I_N$  respectively; the equivalent resistances are found by setting the (independent) sources to zero and simplifying the resulting resistor-network.

**Q4.**

a) Equilibrium,  $t = 0^-$ .

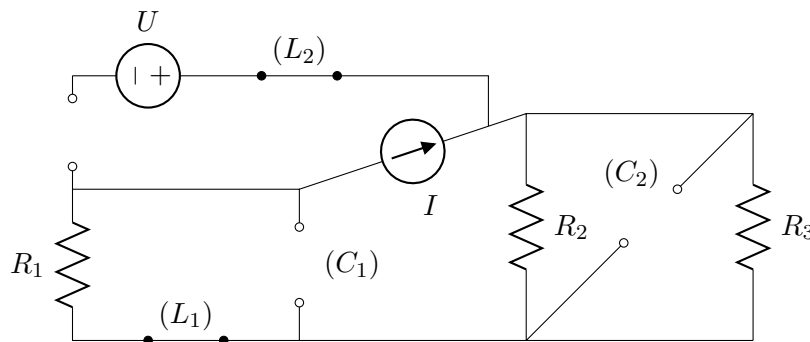

The power supplied from the current source is found by multiplying its current  $I$  by the voltage it, choosing suitable directions or signs so that the power out from the source into the circuit is found. Only

the source and the three resistors need be considered: all other components are irrelevant by being in broken branches or by behaving as open or short circuits when in equilibrium.

$$P_1 = I^2 \left( R_1 + \frac{R_2 R_3}{R_2 + R_3} \right).$$

**b)** Immediately after disturbance of equilibrium (switch),  $t = 0^+$ .

The energy stored in  $C_1$  is determined by the voltage across  $C_1$ ; as this is continuous, it is the same as in the equilibrium at  $t = 0^-$ . Looking at the diagram used in solution 'a', we see that  $C_1$  is in parallel with  $R_1$ , and that all of the current  $I$  must pass through  $R_1$ . The voltage across  $C_1$  is therefore  $IR_1$ , so the stored energy in  $C_1$  is

$$W_{C_1} = \frac{1}{2} C_1 (IR_1)^2.$$

The power absorbed by  $R_3$  can be found by the voltage across it. This resistor is connected in parallel with  $C_2$ , so they have the same voltage. Capacitor voltages are continuous quantities, so this voltage at  $t = 0^+$  is the same as in the equilibrium at  $t = 0^-$ ,

$$P_{R_3} = \frac{u(0^+)_{R_3}^2}{R_3} = \frac{u(0^-)_{R_3}^2}{R_3} = \frac{\left( I \frac{R_2 R_3}{R_2 + R_3} \right)^2}{R_3} = I^2 R_3 \left( \frac{R_2}{R_2 + R_3} \right)^2.$$

It might interest you to notice that just after the switch closes ( $t = 0^+$ ) the only quantities that change in the circuit are the switch voltage (stepping to zero) and the inductor voltage (making the opposite step to the switch voltage). The inductor's continuity (strömtröghet) prevents the rest of the circuit being initially affected: it still behaves as an open circuit. The voltage newly across it causes a current to build up, which will gradually change other quantities in the circuit. However, even if the inductor had been replaced by a short-circuit (so the switch would have immediately connected the voltage source in parallel with the current source) the two solutions in this part 'b' would have been the same, as they depended on the continuity of the capacitors in this circuit.

**c)** Equilibrium,  $t \rightarrow \infty$ .

This is quite a similar circuit to the equilibrium at  $t = 0^-$ , except that now the voltage source and current source appear in parallel, so the rest of the circuit sees them as a voltage source only.

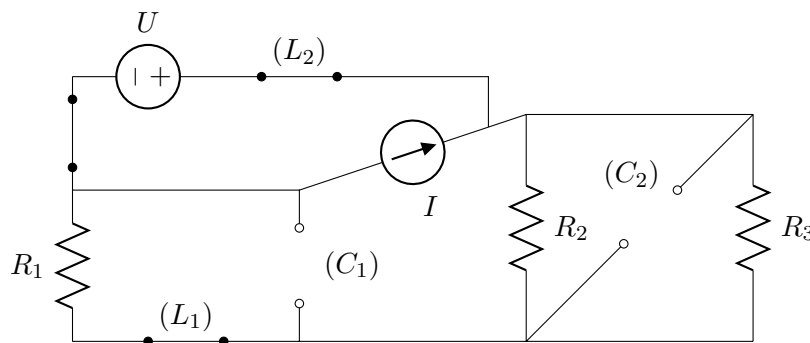

The power absorbed by  $R_1$  is found by first determining the current around the loop,

$$P_{R_1} = i_{R_1}^2 R_1 = \left( \frac{U}{R_1 + \frac{R_2 R_3}{R_2 + R_3}} \right)^2 R_1 = U^2 R_1 \left( \frac{R_2 + R_3}{R_1 R_2 + R_2 R_3 + R_3 R_1} \right)^2.$$

The energy stored in  $L_2$  depends on the current in it. This current, by KCL, is the difference between the current up  $R_1$  and the current  $I$ .

$$W_{L_2} = \frac{1}{2} L_2 (i_{R_1} - I)^2 = \frac{1}{2} L_2 \left( \frac{U}{R_1 + \frac{R_2 R_3}{R_2 + R_3}} - I \right)^2.$$

**Q5.**

In the time-period of interest,  $t > 0$ , the switch is closed and the circuit behaves like the Norton equivalent from Q3-b connected at terminals a-b to a capacitor  $C$ . The time-constant of this circuit is

$$\tau = CR_N = \frac{CR_1R_2}{R_1 + R_2}.$$

Before this period starts,  $t = 0^-$ , there is an equilibrium; so the capacitor has no current. In that case, the voltage across the capacitor is the open-circuit voltage of the circuit. The final state is another equilibrium. The voltage across the capacitor is the open-circuit voltage of the new circuit (switch closed). From the equivalents in Q3-a and Q3-b, these open-circuit voltages are

$$u_{oc}(t < 0) = U_T = IR_2 \quad \text{and} \quad u_{oc}(t > 0) = I_N R_N = \frac{UR_2 + IR_1R_2}{R_1 + R_2}.$$

**Example Method i) Work with the continuous quantity.**

The continuous quantity in this circuit is the capacitor's voltage; let's call this  $u$ , defined as terminal 'a' relative to terminal 'b'. From the paragraphs above, we know the time-constant, the final value of  $u$ , and the initial value of  $u$  (by continuity from the equilibrium at  $t = 0^-$ ).

As this is a first-order circuit (one capacitor or inductor), we expect an exponentially decaying transition from the initial to the final value,

$$u(t) = u(\infty) + (u(0) - u(\infty)) e^{-t/\tau} = \frac{UR_2 + IR_1R_2}{R_1 + R_2} + \left( IR_2 - \frac{UR_2 + IR_1R_2}{R_1 + R_2} \right) e^{-t \frac{R_1 + R_2}{R_1R_2C}}$$

$$u(t) = \frac{UR_2 + IR_1R_2}{R_1 + R_2} + \frac{IR_2^2 - UR_2}{R_1 + R_2} e^{-t \frac{R_1 + R_2}{R_1R_2C}} = \frac{U + IR_1 + (IR_2 - U) e^{-t \frac{R_1 + R_2}{R_1R_2C}}}{(R_1 + R_2)/R_2} \quad (t > 0).$$

It was in fact the current through the capacitor (from 'a' to 'b') that we were supposed to find. This can be calculated from the voltage by  $i(t) = C \frac{du(t)}{dt}$ ; note that if either  $i$  or  $u$  were defined in the opposite direction, a negative sign would be needed in the expression.

$$i(t) = C \frac{du(t)}{dt} = C \cdot \frac{-(R_1 + R_2)}{R_1R_2C} \cdot \frac{IR_2 - U}{(R_1 + R_2)/R_2} e^{-t \frac{R_1 + R_2}{R_1R_2C}} = \frac{U - IR_2}{R_1} e^{-t \frac{R_1 + R_2}{R_1R_2C}} \quad (t > 0).$$

**Example Method ii) Work directly with the sought quantity.**

Instead of finding  $u(t)$  then obtaining  $i(t)$  from this, we could have used initial and final values of  $i(t)$  directly. The potential trap with this is that  $i$  is not a continuous quantity: in this circuit it will have a step when the switch closes. We have to be careful to use  $i(0^+)$ , not  $i(0^-)$ , as the initial value.

At the time  $t = 0^+$ , the capacitor behaves like a voltage source of  $IR_2$ , and the rest of the circuit behaves like the Norton equivalent shown in Q3-b. We can find the current  $i(0^+)$  in the capacitor by analysing the parallel connection of  $I_N$ ,  $R_N$ , and a voltage-source  $IR_2$ . The voltage source determines the current down the Norton resistor; by KCL between this current and the Norton source current, the voltage in the voltage source (capacitor) is found:

$$i(0^+) = I_N - \frac{IR_2}{R_N} = \frac{U}{R_1} + I - IR_2 \frac{R_1 + R_2}{R_1R_2} = \frac{U}{R_1} - I \frac{R_2}{R_1}.$$

Then the initial/final/time method can be applied directly to current, bearing in mind that the final current is zero, as required for a capacitor current in equilibrium,

$$i(t) = i(\infty) + (i(0) - i(\infty)) e^{-t/\tau} = 0 + \left( \frac{U}{R_1} - I \frac{R_2}{R_1} - 0 \right) e^{-t/\tau} = \frac{U - IR_2}{R_1} e^{-t \frac{R_1 + R_2}{R_1R_2C}} \quad (t > 0).$$

Lots of other methods can of course be chosen, including ones that don't take advantage of the Thevenin or Norton equivalents derived in Question 3.