

*Permitted material:* Beyond writing-equipment, up to three pieces of paper up to A4 size can be used, with free choice of content: handwritten, printed; small, large; text, diagram, image; one or both sides, etc. These papers do not need to be handed in with the exam.

Unless it is stated otherwise, the final answer to a question should be expressed in terms of the known quantities given in the question, and any clear simplifications should be done. Component values such as  $R$  for a resistor,  $U$  for an independent voltage source, or  $K$  for a dependent source, are assumed to be known quantities. Marked currents or voltages such as  $i_x$  are assumed to be definitions, not known quantities.

Clearly drawn and labelled diagrams are a good way to help yourself avoid mistakes, and to make clear to others what you are doing. By showing clearly your intermediate steps in a solution, you improve your chance of getting points even if the final result is wrong. You may write in Swedish or English; but we suggest that writing in either is seldom necessary if you make good use of diagrams and equations!

*Determination of exam grade.* Denote as  $A$ ,  $B$  and  $C$  the available points from sections A, B and C of this exam:  $A=12$ ,  $B=10$ ,  $C=18$ . Denote as  $a$ ,  $b$  and  $c$  the points actually obtained in the respective sections, and as  $a_k$  and  $b_k$  the points from KS1 and KS2, and as  $h$  the homework ‘bonus’. The requirement for passing the exam (E or higher) is:

$$\frac{\max(a, a_k)}{A} \geq 40\% \quad \& \quad \frac{\max(b, b_k)}{B} \geq 40\% \quad \& \quad \frac{c}{C} \geq 40\% \quad \& \quad \frac{\max(a, a_k) + \max(b, b_k) + c + h}{A + B + C} \geq 50\%$$

The grade is then determined by the total including bonus, i.e. the last of the terms above: boundaries (%) are 50 (E), 60 (D), 70 (C), 80 (B), 90 (A). If the exam misses a pass by a small margin on just one criterion, a grade of Fx may be registered, with the possibility of completing to E by an extra task arranged later.

*Special for the VT21 round:*

The exam is conducted remotely, monitored in a video meeting.

Answers must be in handwriting: either on paper that is scanned or photographed, or by handwriting into a computer by means of a suitable touchscreen or pad.

In selecting whether to use points from the exam or part-exams (‘KS’), the selection will be done per question, not just per section.

The course’s optional project-task substitutes for Question 9 in this exam if that gives an advantage.

Nathaniel Taylor (08 790 6222)

## Section A. Direct Current

1) [4p]

Determine:

- a) [1p] the power into  $R_2$
- b) [1p] the marked voltage  $u_a$
- c) [1p] the marked current  $i_b$
- d) [1p] the power from source  $I_2$

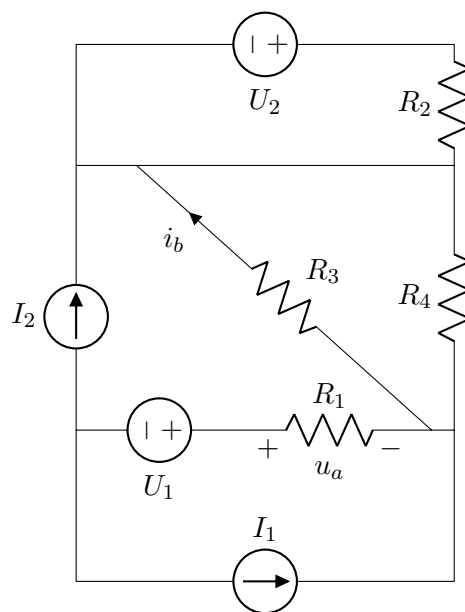

2) [4p]

Write equations that could be solved without further information to find the potentials  $v_1, v_2, v_3$  and  $v_4$  in this circuit in terms of the component values.

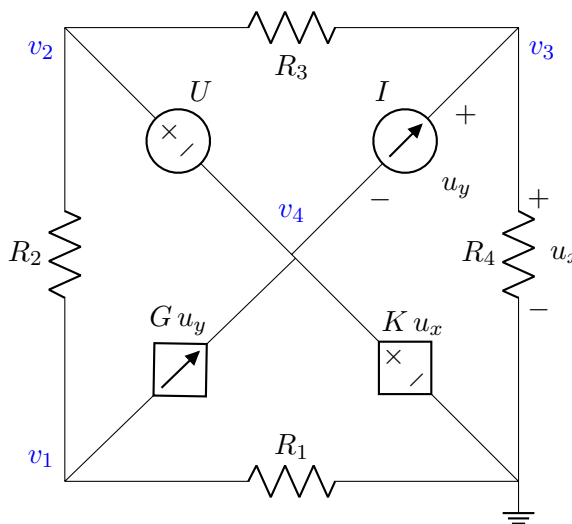

3) [4p]

Determine the Thevenin equivalent between:

a) [3p] Terminals a and b.

b) [1p] Terminals c and d.

Note! low points for the work.

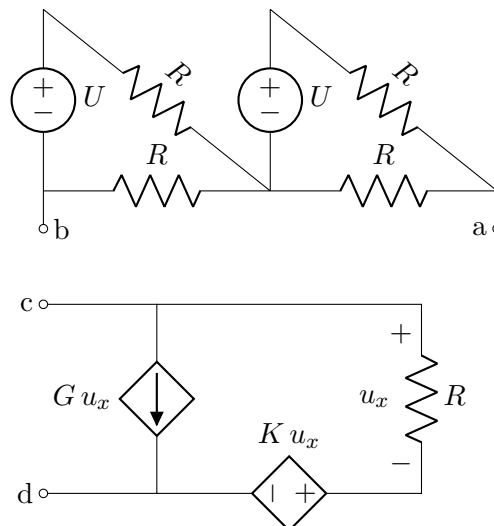

---

## Section B. Transient Calculations

---

4) [5p] Determine the:

- a) [1p] energy stored in  $L_1$  at  $t = 0^-$
- b) [1p] power into  $R_3$  at  $t = 0^+$
- c) [2p] power out of  $C_1$  at  $t = 0^+$
- d) [1p] energy stored in  $C_1$  as  $t \rightarrow \infty$

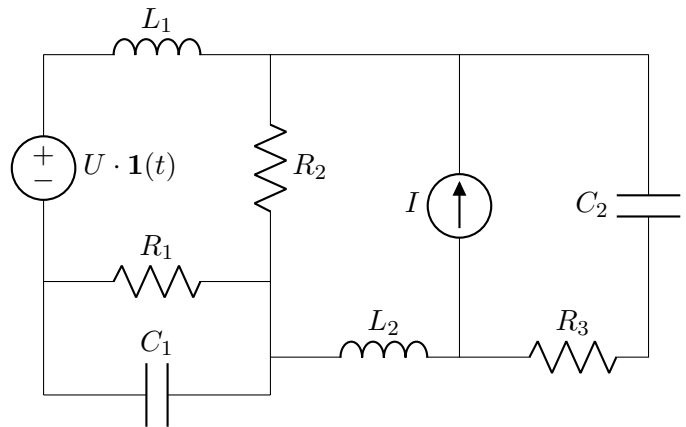

5) [5p]

a) [3p] Determine  $i(t)$  for  $t > 0$ , for the upper circuit.

b) [2p] Determine  $i(t)$  for  $t > 0$ , for the lower circuit, i.e. the circuit with a dependent source.

*Note!* If you get this solution right, it will provide the points for part 'a' as well, so you get all 5 points for solving just the lower circuit. But solving the upper circuit too might be good for safety, in case of mistakes with the more difficult solution.

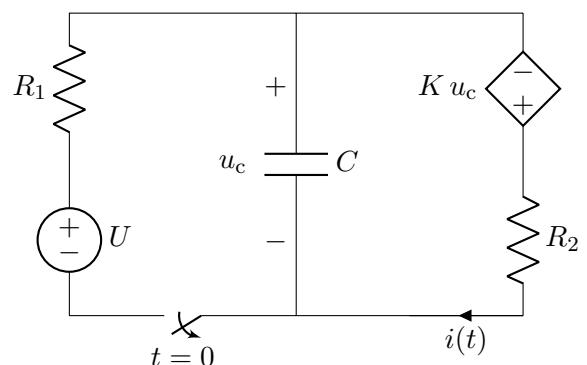
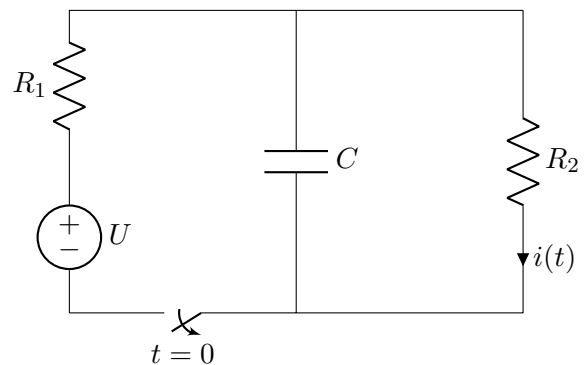

---

## Section C. Alternating Current

---

6) [4p]

Determine  $i(t)$ .

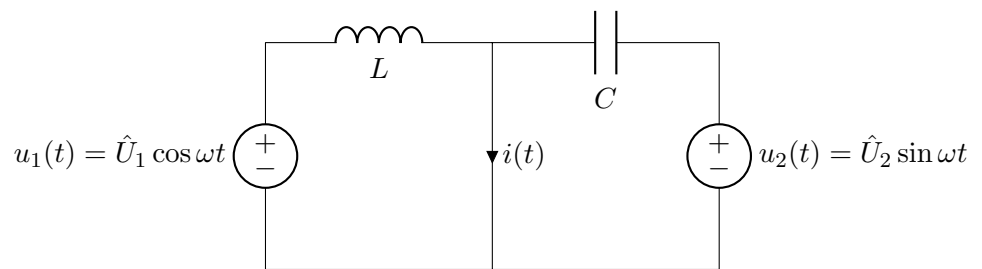

7) [4p]

a) [2p] Show that this circuit's network function  $H(\omega) = \frac{u_o}{u_i}$  can be expressed as

$$H(\omega) = \frac{-(1 + j\omega/\omega_1)}{j\omega/\omega_0 (1 + j\omega/\omega_2)}$$

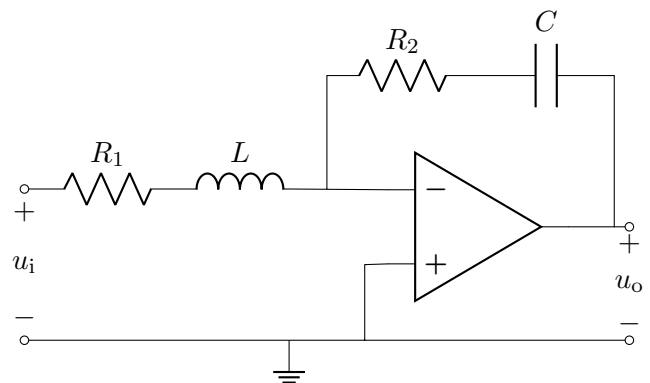

b) [2p] Sketch a Bode amplitude plot of the above network function, given that  $100\omega_0 = \omega_1$  and  $\omega_1 \ll \omega_2$ . Mark significant points and gradients.

8) [4p]

The source has angular frequency  $\omega$ .  
All the component values are fixed.

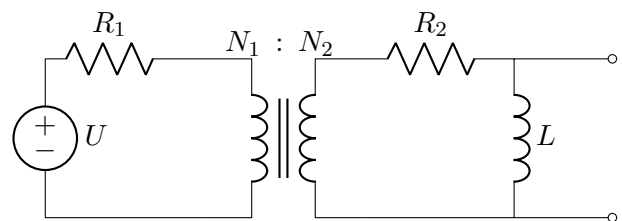

A resistor  $R_x$  and capacitor  $C_x$  are connected in parallel to the terminals at the right of the circuit.

a) [3p] What values of  $R_x$  and  $C_x$  should be chosen in order to maximize the power going into  $R_x$ ? Express them in terms of the component values in the shown circuit.

b) [1p] With  $R_x$  and  $C_x$  chosen as requested in 'a', express the power transferred into  $R_x$ .

9) [6p]

The diagram below shows a balanced three-phase system. A three-phase voltage source supplies the primary side of a transformer that is formed from three single-phase transformers, all with  $N_1 : N_2$  ratio. A resistive load is connected to the secondary side.

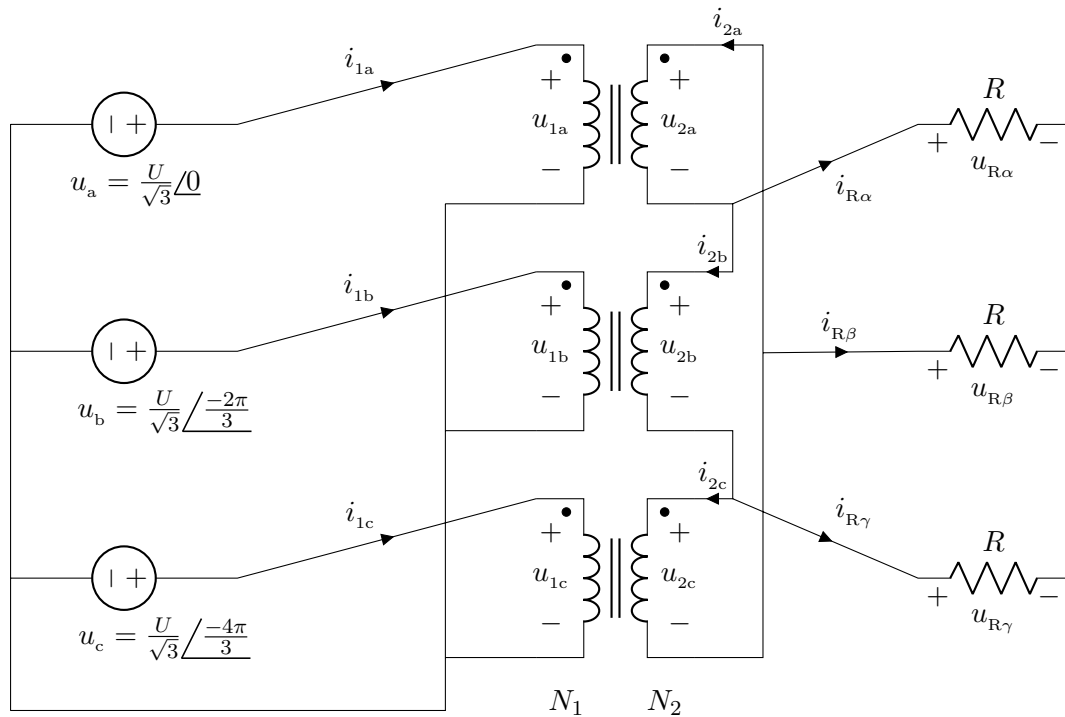

Note that straight lines crossing each other in this diagram do *not* indicate a connection. Connections here involve three lines stopping at a single point.

- [2p] What is the voltage magnitude across each load resistor? For example,  $|u_{R\beta}|$ .
- [1p] What complex power does the source supply?
- [2p] What is  $u_{2c}$  as a phasor: magnitude and angle?
- [1p] What is the angle of  $u_{R\gamma}$ ?

**The End.**

*Please don't waste remaining time ... check your solutions!*

## Översättningar:

*Hjälpmedel:* Upp till tre A4-ark (båda sidor) med studentens egna anteckningar på valfritt sätt: handskrivet eller datorutskrift; text, diagram, bild; stor eller liten textstorlek, o.s.v. Dessa måste inte lämnas in med skrivningarna.

Om inte annan information anges i ett tal ska: komponenter antas vara ideala; angivna värden av komponenter (t.ex.  $R$  för ett motstånd,  $U$  för en spänningskälla,  $K$  för en beroende källa) antas vara *kända* storheter; och andra markerade storheter (t.ex. strömmen markerad i ett motstånd eller spänningskälla) antas vara *okända* storheter. Lösningar ska uttryckas i kända storheter och förenklas.

Var tydlig med diagram och definitioner av variabler. Du får skriva på svenska eller engelska, men vi rekommenderar att diagram och ekvationer används i stället i de flesta fall.

1. [4p] Bestäm följande:

- [1p] effekten in till  $R_2$
- [1p] den markerade spänningen  $u_a$
- [1p] den markerade strömmen  $i_b$
- [1p] effekten från källan  $I_2$

2. [4p] Skriv ekvationer som skulle *kunna* lösas, utan vidare information, för att bestämma potentialerna  $v_1$ ,  $v_2$ ,  $v_3$  och  $v_4$ , som funktioner av kretsens komponentvärden. Det rekommenderas inte att du försöker lösa ekvationerna!

3. [4p] Bestäm Theveninekvivalenten mellan:

- [3p] polerna a och b,
- [1p] polerna c och d.

4. [5p] Bestäm:

- [1p] energin lagrad i  $L_1$  vid  $t = 0^-$
- [1p] effekten in till  $R_3$  vid  $t = 0^+$
- [2p] effekten från  $C_1$  vid  $t = 0^+$
- [1p] energin lagrad i  $C_1$  vid  $t \rightarrow \infty$ .

5. [5p] Bestäm, för  $t > 0$ :

- [3p]  $i(t)$  i den övre kretsen (utan beroende spänningskälla),
- [2p]  $i(t)$  i den lägre kretsen (med beroende spänningskälla).

*Obs!* Hela 5 poäng för tal 5 erhålls vid korrekt lösning av deltal 'b'. Men lösning av deltal 'a' kan vara en bra säkerhet då lösning av 'b' kanske misslyckas.

6. [4p] Bestäm  $i(t)$  (genom växelströmsanalys).

7. [4p]

- [2p] Visa att kretsen har den angivna nätverksfunktion (se ekvationen till vänster om diagrammet).
- [2p] Skissa ett Bodeamplituddiagram av  $H(\omega)$  som given i deltal 'a'. Antag  $100\omega_0 = \omega_1$  och  $\omega_1 \ll \omega_2$ . Markera viktiga punkter och lutningar.

8. [4p] Källan har vinkelfrekvens  $\omega$ . Komponentvärden i kretsen är fasta.

- [3p] Motstånd  $R_x$  och kapacitans  $C_x$  parallellkopplas till polerna som visas till höger. Vilka värden ska dessa ha, uttryckta i diagrammets komponentvärden, för att maximeffekt överförs till  $R_x$ ?
- [1p] Hur mycket aktiveffekt kommer till  $R_x$  när  $R_x$  och  $C_x$  väljs enligt 'a'?

9. [6p]

- [2p] Vad är det för spänningsmagnitud på varje lastmotstånd, t.ex.  $|u_{R\beta}|$ ?
- [1p] Vilken komplexeffekt matas från källan?
- [2p] Vad är  $u_{2c}$  som fasvektor (magnitud och fas)?
- [1p] Hur mycket är vinkeln av  $u_{R\gamma}$ ?

# Solutions (EI1120 TEN1 VT21, 2021-03-17)

## Q1

a.  $P_{R_2} = \frac{U_2^2}{R_2}$

KVL around the top loop.

b.  $u_a = -(I_1 + I_2) R_1$

KCL at the left of  $U_1$  shows that a current of  $I_1 + I_2$  passes from right to left in  $R_1$ . The direction of  $u_a$  is such that this current comes out from the + side of the voltage, so a negative sign is needed in Ohm's law.

c.  $i_b = \frac{-I_2 R_4}{R_3 + R_4}$

Current division between  $R_3$  and  $R_4$ , noting the backward direction. KCL at the node above  $I_2$  shows that exactly this source's current passes down through the two parallel resistors.

d.  $P_{I_2} = I_2 \left( U_1 + (I_1 + I_2) R_1 + \frac{I_2 R_3 R_4}{R_3 + R_4} \right)$

The power out from this source is the product of its current  $I_2$  and its voltage, marked  $u_x$  on the diagram to the right. To find  $u_x$  we apply KVL. The smallest useful loop is through  $R_3$  or  $R_4$ , then  $R_1$  and  $U_1$ , giving the KVL equation  $u_x = U_1 - u_a - i_b R_3$ .

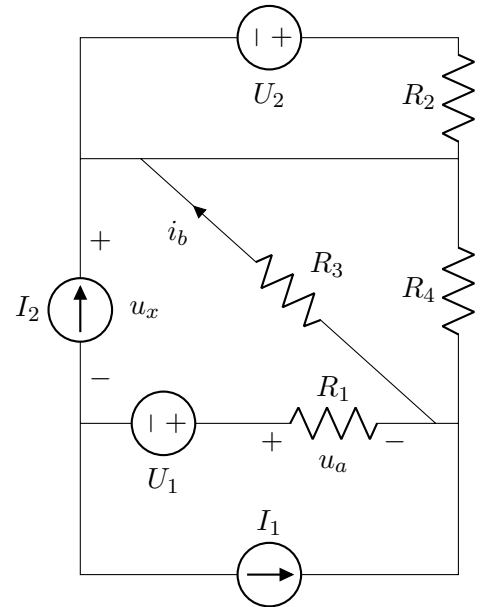

## Q2

### I. Extended nodal analysis

Write KCL at every node except the reference (earth) node.

Define the unknown currents in voltage sources: here we have defined them as  $i_\alpha$  and  $i_\beta$ .

$$\text{KCL(1)}_{(\text{out})} : 0 = \frac{v_1}{R_1} + \frac{v_1 - v_2}{R_2} + G u_y \quad (1)$$

$$\text{KCL(2)}_{(\text{out})} : 0 = \frac{v_2 - v_1}{R_2} + \frac{v_2 - v_3}{R_3} + i_\alpha \quad (2)$$

$$\text{KCL(3)}_{(\text{out})} : 0 = \frac{v_3 - v_2}{R_3} + \frac{v_3}{R_4} - I \quad (3)$$

$$\text{KCL(4)}_{(\text{out})} : 0 = I - G u_y - i_\alpha + i_\beta \quad (4)$$

Then write the constraints that the voltage sources put on the node potentials.

$$v_2 - v_4 = U \quad (5)$$

$$v_4 = K u_x \quad (6)$$

Finally, express the definitions of the marked quantities that control dependent sources.

$$u_x = v_3 \quad (7)$$

$$u_y = v_3 - v_4 \quad (8)$$

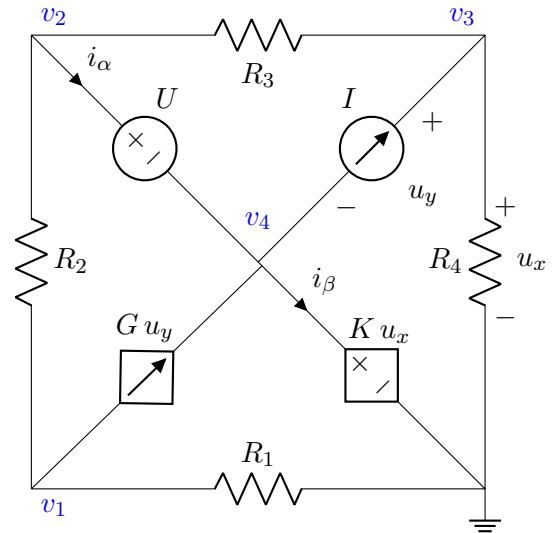

The above are 8 equations in 8 unknowns:  $v_1, v_2, v_3, v_4, i_\alpha, i_\beta, u_x, u_y$ . Having followed the rules, we expect them to be independent equations.

### II. Nodal analysis by simplifications including supernodes

The nodes with potentials  $v_4$  and  $v_2$  are connected to each other and to the reference node through voltage sources. Their potentials can therefore be defined in terms of the source voltages:  $v_4 = K v_3$ , and  $v_2 = v_4 + U = U + K v_3$ . They can be said to form a single supernode: we do no KCL on it, as it includes the reference node.

We write these two nodes' potentials in terms of the known quantities (component values) and the other potentials (the ones that we'll include in KCL).

$$v_4 = K v_3 \quad (1)$$

$$v_2 = U + K v_3 \quad (2)$$

The remaining two nodes have potentials that we must find by KCL. We define  $v_1$  and  $v_3$  as unknowns, and write KCL for these nodes in terms of just these two unknowns. KCL at node 1 would include a current  $G u_y$ , which includes the further unknown  $u_y$ , so we first try to express this in terms of  $v_1, v_3$  and component values. The definition of  $u_y$  is across the current source  $I$ , from which we see that  $u_y = v_3 - v_4$ . Substituting the above expression for  $v_4$  gives  $u_y = v_3(1 - K)$ .

$$\frac{v_1 - (U + K v_3)}{R_2} + \frac{v_1}{R_1} + (1 - K)G v_3 = 0 \quad (3)$$

$$\frac{v_3 - (U + K v_3)}{R_3} - \frac{v_3}{R_4} - I = 0 \quad (4)$$

These two KCLs can be solved together to find  $v_1$  and  $v_3$ , after which the earlier two equations can be used to find  $v_4$  and  $v_2$ .



### Q3

a.  $U_T = U$  and  $R_T = R$ .

Several methods all seem quite sensible for this solution.

Some of them can be simplified by seeing the circuit as two identical ‘units’ in series. If the equivalent for one unit is found, the equivalent for both in series will have twice as much voltage and resistance.

- Nodal analysis to find the  $u, i$  relation. For example, define node ‘b’ as zero, in which just node ‘a’ and the middle node are independent potentials.

However, it’s easier to take just one of the two identical parts in the circuit. If we define the middle point at 0 and define a current  $i$  out of terminal ‘a’, KCL gives  $i + \frac{v_a}{R} + \frac{v_a - U}{R}$ , from which  $v_a = U/2 + iR/2$ . We get the solution by identifying  $U_T$  and  $R_T$  from this  $u, i$  relation, and doubling them for the case of two similar series-connected units.

- Find the open-circuit voltage by looking at the two loops, which are independent (no current going between them) when the shown terminals are open-circuit. This voltage is the sum of voltages across the 2 identical voltage-dividers, which both divide by 2. There are no dependent sources to cause trouble here, so we can find the Thevenin resistance by setting the sources to zero, which gives a series connection of two parallel pairs of resistors.

- Source transformation, turning each of the two identical units in the circuit into two parallel resistors  $R$  and a parallel current source  $U/R$ . Then consider short-circuit current and equivalent resistance.

- Superposition. This might help the circuit to look more friendly. Due to the symmetry, the calculation would be identical for each of the two superposition states.

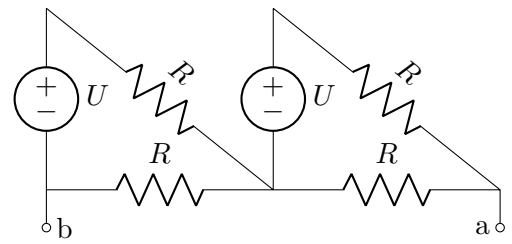

b.  $U_T = 0$  and  $R_T = \frac{1 + K}{G + \frac{1}{R}}$ .

Mark the voltage and current at the terminals:  $u$  and  $i$  in the diagram shown here. Here the active convention has been chosen, with current defined in the direction out of the +–side of the voltage, even though the circuit has no independent source. This fits with what we’ve usually done for a ‘Thevenin source’.

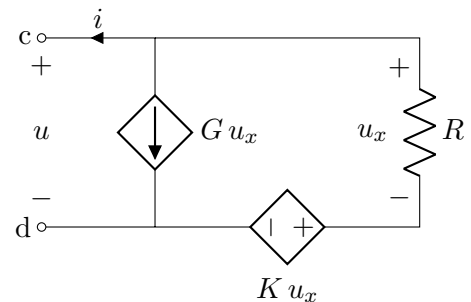

Here, writing a relation between  $u$  and  $i$  looks a good idea. The presence of dependent sources prevents the method of just simplifying resistors after setting all independent sources to zero.

Taking KCL at the top node,  $i + G u_x + u_x/R = 0$ .

This gives a relation of  $i$  to  $u_x$ , without  $u$ .

A KVL in the outer loop expresses  $u_x$  in terms of  $u$  as  $u = (1 + K)u_x$ .

From the above,

$$i = \frac{-(G + \frac{1}{R})}{1 + K} u,$$

so

$$u = 0 - \frac{1 + K}{G + \frac{1}{R}} i.$$

Comparing this to the  $u, i$  relation of a Thevenin source,  $u = U_T - R_T i$ , we find the Thevenin component values.

### Q4

The original circuit is shown on the right.

Just one change happens over all time, with the voltage source stepping from 0 to  $U$  at time  $t = 0$ .

We have to solve for quantities in the initial ( $0^-$ ) and final ( $\infty$ ) equilibrium states, and just after the step ( $0^+$ ).

For each state we'll draw a simplified diagram.

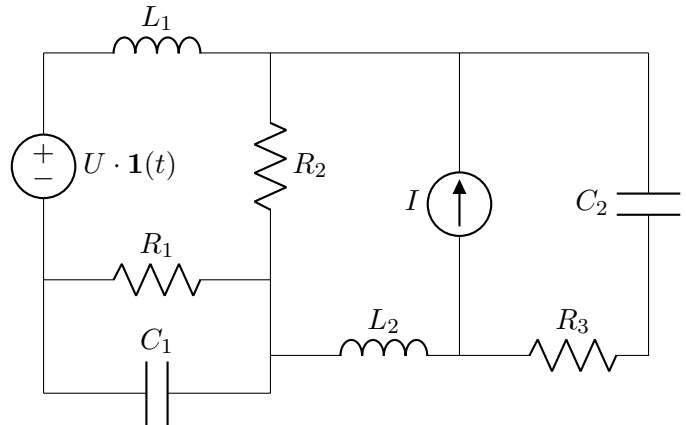

Initial equilibrium,  $t = 0^-$ .

The voltage source still has zero value, so it can be shown as a short-circuit. With no change in current or voltage, inductors have no voltage and capacitors have no current, so they can be simplified as short- or open circuits.

Inductor currents and capacitor voltages are marked here, with directions chosen to give positive expressions. Only  $i_{L1}$  matters to us just now, for finding the energy stored in  $L1$ . However, others of these continuous variables might be useful for calculations at  $t = 0^+$ .

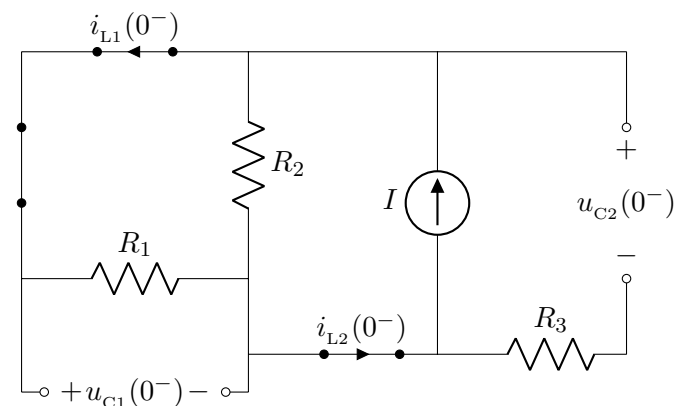

By current division,  $i_{L1} = \frac{IR_2}{R_1 + R_2}$ .

a. 
$$W_{L1}(0^-) = \frac{1}{2} L_1 \left( \frac{IR_2}{R_1 + R_2} \right)^2.$$

Continuity just after the step,  $t = 0^+$ .

Here, the capacitor voltages and inductor currents have not had a chance to change in spite of the voltage-source's change. We can represent them as sources with the values from  $t = 0^-$  that were defined (but not solved) above.

KCL at the left of  $R_3$  shows that the current through  $R_3$  is  $i_{L2}(0^-) - I$ .

Looking back to the earlier, diagram for  $t = 0^-$ , KCL in the same place shows that  $i_{L2}(0^-) = I$ .

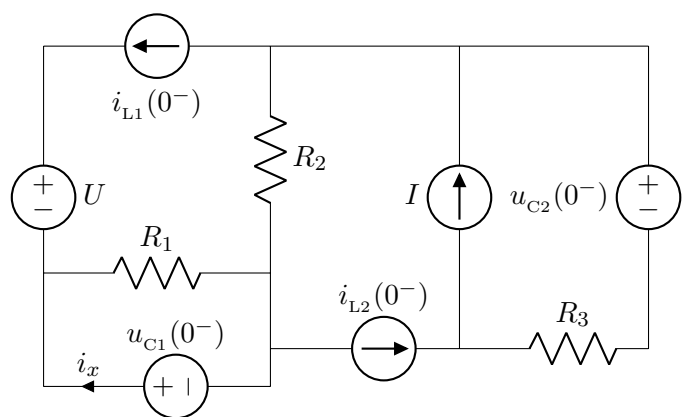

b. 
$$P_{R3}(0^+) = (i_{L2}(0^-) - I)^2 R_3 = (I - I)^2 R_3 = 0.$$

The power out of  $C_1$  is  $u_{C1} i_x$ , where  $i_x$  is the current shown above, defined out of the  $+$  terminal of the voltage source that represents  $C_1$  at  $t = 0^+$ .

The current in  $R_1$  is fixed by KVL and Ohm's law, around  $C_1$  and  $R_1$ .

The current down through source  $U$  is fixed by the inductor's current  $i_{L1}(0^-)$ .

KCL gives  $i_x$  in terms of the above two currents,

$$i_x = \frac{-u_{C1}(0^-)}{R_1} - i_{L1}(0^-).$$

Then use the diagram for  $t = 0^-$  to calculating the values of the continuous quantities such as  $u_{C1}(0^-)$ ,

$$i_x = \frac{-\frac{IR_1R_2}{R_1+R_2}}{R_1} - \frac{IR_2}{R_1+R_2} = -2\frac{IR_2}{R_1+R_2}.$$

Multiply this current by the capacitor's voltage to give the power out,

$$\text{c. } P_{C1}(0^+) = i_x(0^+)u_{C1}(0^-) = -2\frac{IR_2}{R_1+R_2} \cdot \frac{IR_1R_2}{R_1+R_2} = \frac{-2R_1R_2^2I^2}{(R_1+R_2)^2}.$$

Final equilibrium,  $t \rightarrow \infty$ .

In order to find the energy stored in  $C_1$  at this time, we should find this capacitor's voltage,  $u_{C1}(\infty)$ .

It is harder than at  $t = 0^-$ , because the source  $U$  prevents  $R_1$  and  $R_2$  being in parallel.

Superposition is a convenient method:

With source  $U$  alone, the only current-loop is around  $U$ ,  $R_2$ ,  $R_1$ .

Voltage division gives  $u_{C1,(U)}(\infty) = \frac{-R_1U}{R_1+R_2}$ .

With source  $I$  alone, the zeroed voltage source causes  $R_1$  and  $R_2$  to be in parallel.

Current division gives  $u_{C1,(I)}(\infty) = \frac{R_1R_2I}{R_1+R_2}$ .

Adding both of the above partial results,  $u_{C1}(\infty) = \frac{R_1R_2I - R_1U}{R_1+R_2}$ .

$$\text{d. } W_{C1}(\infty) = \frac{1}{2} C_1 \left( \frac{R_1R_2I - R_1U}{R_1+R_2} \right)^2.$$

*A note:* The only change in this circuit was the step in the voltage source. This source is in series with an inductor, which initially causes the current through their branch to remain the same as before the step. Therefore, we can expect all other quantities in the circuit (outside this branch) are identical at  $t = 0^-$  and  $t = 0^+$ . If one wants a name for the principle, one option is 'substitution theorem': in a given circuit, changing a component for any other one that will give the same voltage or current will give the same results in the circuit.

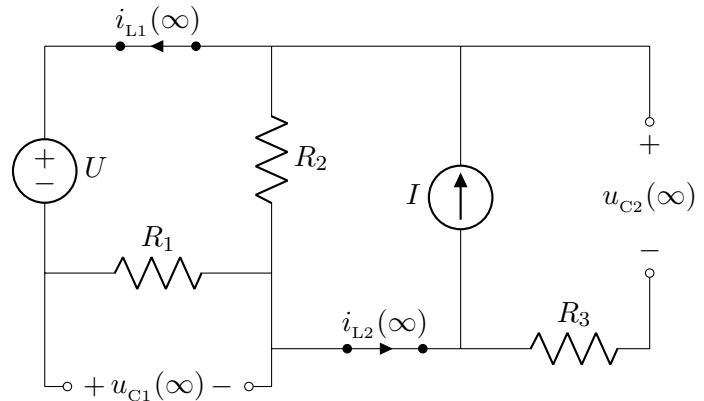

**Q5**

Consider first the initial condition. The capacitor's continuous quantity is voltage. We find the voltage on the capacitor in the equilibrium at  $t = 0^-$ , before the switch closes.

The capacitor is then seen as an open-circuit (equilibrium), so current flows only in the outer loop.

By KVL in the loop on the right, the capacitor's voltage is the same as the voltage across  $R_2$ . Voltage division gives the voltage across  $R_2$  as  $\frac{UR_2}{R_1+R_2}$ .

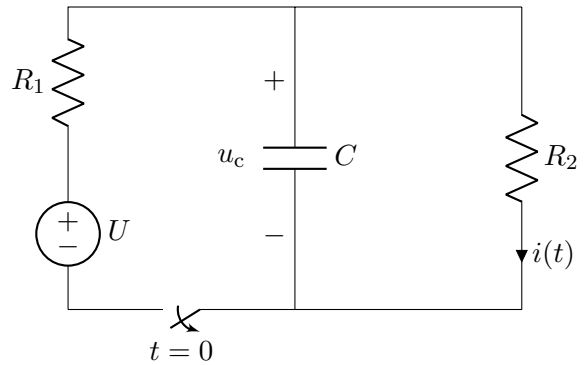

By continuity, the capacitor's voltage remains the same immediately after the circuit changes, so  $u_c(0^+) = u_c(0^-) = \frac{UR_2}{R_1+R_2}$ .

After the switch opens, the left branch is disconnected. The capacitor is connected only to  $R_2$ , so it discharges through  $R_2$ .

The final equilibrium state of the capacitor's voltage is therefore  $u_c(\infty) = 0$ .

By continuity, the capacitor's voltage remains the same immediately after the circuit changes, so  $u_c(0^+) = u_c(0^-) = \frac{UR_2}{R_1+R_2}$ .

The time-constant is simply  $CR_2$ .

Putting the above together to fit the expected exponential decay,

$$u_c(t) = u_c(\infty) + (u_c(0^+) - u_c(\infty)) e^{-t/\tau} = \frac{UR_2}{R_1 + R_2} e^{-t/CR_2}.$$

Up to here we've focused on finding the continuous quantity  $u_c(t)$ . From this we can find other quantities in the circuit. In this case, we want to find the marked  $i(t)$ . Two methods of doing this are given below.

After the switch opens, the marked current  $i$  is the same as the current coming out from the top end of the capacitor. This follows from KCL at the top node, with the left branch open-circuit. Therefore,

$$i(t) = -C \frac{du_c(t)}{dt} = -C \frac{-1}{CR_2} \frac{UR_2}{R_1 + R_2} e^{-t/CR_2} = \frac{U}{R_1 + R_2} e^{-t/CR_2}.$$

An alternative, rather easier method uses KVL and Ohm's law,

$$i(t) = \frac{u_c(t)}{R_2} = \frac{U}{R_1 + R_2} e^{-t/CR_2}.$$

**b.** Who would have thought that adding one little dependent source would make it so different?

It's not very surprising, really, as dependent sources are nasty, and even adding one resistor can sometimes make a circuit much more work to solve.

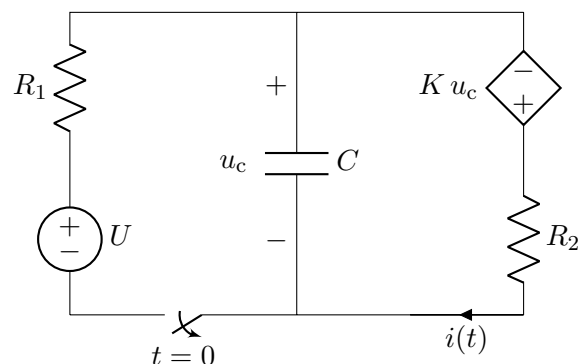

In the initial equilibrium at  $t = 0^-$ , with the switch closed and no current in the capacitor, we can take KCL at the top node,

$$\frac{u_c - U}{R_1} + \frac{u_c + K u_c - 0}{R_2} = 0.$$

This gives

$$u_c \left( \frac{1}{R_1} + \frac{1}{(1+K)R_2} \right) = \frac{U}{R_1}$$

so

$$u_c(0^-) = \frac{U/R_1}{\frac{1}{R_1} + \frac{1}{(1+K)R_2}} = \frac{U(1+K)R_2}{R_1 + (1+K)R_2}.$$

The final equilibrium is still zero, as no source is connected after  $t = 0$  and any voltage on the capacitor will cause a current around  $R_2$  to discharge it. (Or, at least, it will as long as  $K$  isn't  $< -1 \dots$  we'll assume it's a stable circuit.)

The time-constant can be found by considering the Thevenin resistance of what's connected to the capacitor during  $t > 0$ .

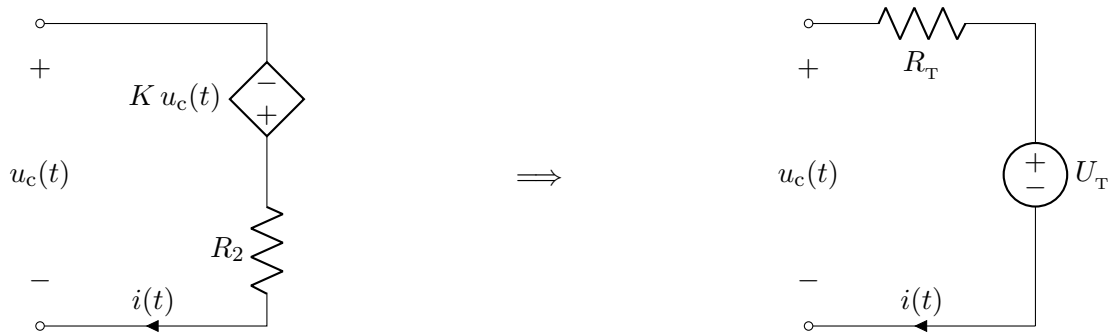

By KVL in the right loop, the relation of the capacitor's voltage  $u_c(t)$  to the current  $i(t)$  out of its + end is,

$$u_c(t) + K u_c(t) = i(t) R_2,$$

$$u_c(t) = 0 + \frac{R_2}{1+K} i(t) = U_T + R_T i(t).$$

The + sign is in contrast to the  $U_T - R_T i(t)$  that we often have seen: it's because this time we just happen to have a current that's defined *into* the + side of the terminal voltage  $u_c$ .

From the above,  $R_T = \frac{R_2}{1+K}$ .

Putting together the initial value, final value and time-constant, as for part 'a',

$$u(t) = \frac{U R_2 / (1+K)}{R_1 + R_2 / (1+K)} e^{-t \frac{1}{C R_2 / (1+K)}} = \frac{U}{1 + (1+K) \frac{R_1}{R_2}} e^{-t \frac{1+K}{C R_2}}.$$

In this circuit with the dependent source, the method of  $i = -C \frac{du_c}{dt}$  still works for finding the marked current  $i$ . The method of KVL and Ohm's law would require a factor  $(1+K)$  to scale the capacitor voltage to be the voltage across the resistor.

$$i(t) = \frac{U}{\left(1 + (1+K) \frac{R_1}{R_2}\right) \frac{R_2}{1+K}} e^{-t \frac{1+K}{C R_2}} = \frac{U(1+K)}{(1+K) R_1 + R_2} e^{-t \frac{1+K}{C R_2}} \quad (t > 0).$$

This could be expressed in many ways, without one clearly being the best 'simplification'.

Note that in this particular circuit, where the dependent voltage source is in series with the resistor and is controlled by the voltage across the pair of them, a bit of 'conceptual' thinking could have told us from the start that this pair of  $K u_c$  and  $R_2$  would behave, from the position of the capacitor, as a resistor of  $R_2/(1+K)$ . Then we could just have substituted  $R/(1+K)$  for  $R_2$  in the earlier solution. The reason is that the dependent source causes  $R_2$  always to see  $(1+K)$  of the voltage that's applied.

## Q6

We are given the time-functions

$$u_1(t) = \hat{U}_1 \cos \omega t,$$

$$u_2(t) = \hat{U}_2 \sin \omega t.$$

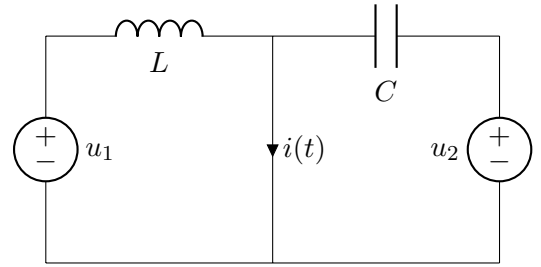

Let's take cosine as the reference phase, and use peak-values. Then we can define

$$u_1(\omega) = \hat{U}_1 / \underline{0} = \hat{U}_1$$

$$u_2(\omega) = \hat{U}_2 / \underline{-\pi/2} = -j\hat{U}_2.$$

The currents around the left and the right loop can be analyzed separately: they only meet at a single node, so we can take two independent KVLs.

$$\text{The current up through the left source is } i_1(\omega) = \frac{u_1(\omega)}{j\omega L}.$$

$$\text{The current up through the right source is } i_2(\omega) = \frac{u_2(\omega)}{1/(j\omega C)}.$$

The marked current is the sum of the above,

$$i(\omega) = i_1(\omega) + i_2(\omega) = \frac{\hat{U}_1}{j\omega L} + (-j\hat{U}_2)(j\omega C) = \omega C \hat{U}_2 - j\hat{U}_1 \frac{1}{\omega L}.$$

For the time-function we need the polar form:

$$|i(\omega)| = \sqrt{(\omega C \hat{U}_2)^2 + \left(\frac{\hat{U}_1}{\omega L}\right)^2} \quad \text{and} \quad \angle i(\omega) = \text{atan} \frac{-\hat{U}_1}{\omega^2 LC \hat{U}_2}.$$

As we chose cosine reference and peak values for transforming from time functions to phasors, we use the same for transforming back:

$$i(t) = \sqrt{(\omega C \hat{U}_2)^2 + \left(\frac{\hat{U}_1}{\omega L}\right)^2} \cos \left( \omega t - \text{atan} \frac{\hat{U}_1}{\omega^2 LC \hat{U}_2} \right).$$

**Q7**

**a.** This is a classic inverting amplifier, but with the input and feedback impedances are made up of more than a single component each.

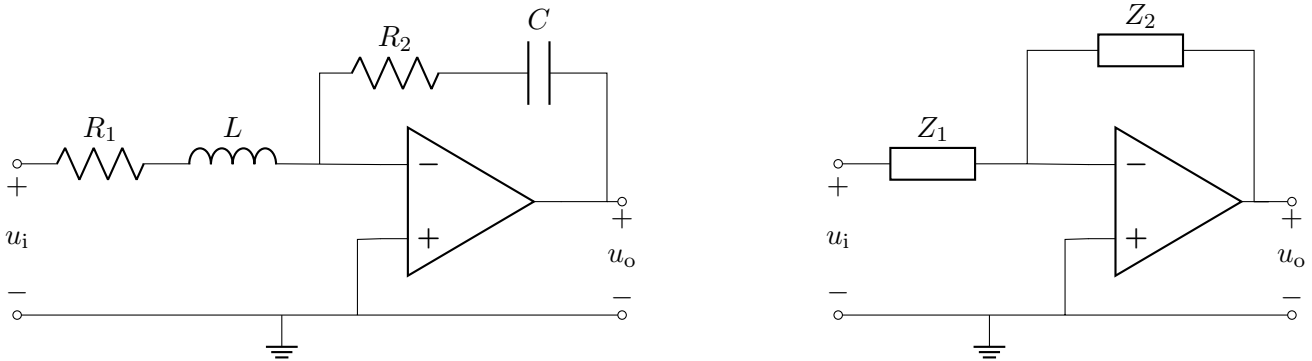

$H(\omega)$  can be found from KCL at the inverting input, where the potential must be 0 in order to match the non-inverting input:  $\frac{0-u_i}{Z_1} + \frac{0-u_o}{Z_2} + 0 = 0$ .

Alternatively, one can make direct use of the standard result for an inverting amplifier,  $u_o/u_i = -Z_2/Z_1$ .

$$H(\omega) = \frac{u_o}{u_i} = \frac{-Z_2}{Z_1} = \frac{-(R_2 + \frac{1}{j\omega C})}{R_1 + j\omega L}$$

The classic form with  $(1 + j\omega/\omega_x)$  terms can be obtained here by multiplying top and bottom by  $j\omega C$ , then bringing a factor  $R_1$  out from the parentheses at the bottom.

$$H(\omega) = \frac{-(j\omega C R_2 + 1)}{j\omega C (R_1 + j\omega L)} = \frac{-(1 + j\omega C R_2)}{j\omega C R_1 (1 + j\omega L/R_1)} = \frac{-(1 + j\omega/\omega_1)}{j\omega/\omega_0 (1 + j\omega/\omega_2)}$$

The final step in the above shows that  $\omega_0 = \frac{1}{CR_1}$ ,  $\omega_1 = \frac{1}{CR_2}$ ,  $\omega_2 = \frac{R_1}{L}$ .

**b.** In the example on the right, only the solid blue line is required as the solution.

The vertical axis should be in dB, and should have 0 dB marked.

The frequency scale should be logarithmic, to give straight lines in the Bode amplitude plot. All three frequency-points such as  $\omega_1$  should be marked. It doesn't matter whether the notation uses  $\omega$  or  $f$  or  $\log \omega$ , etc.

The lowest frequency, with subscript 0, is where the plot passes through 0 dB.

The intermediate frequency, with subscript 1, is 100 times as high as the lower one, so the plot at this point has a level  $-40$  dB, which should be marked.

The highest frequency is where the second denominator term 'turns on', so now the line starts falling again. If the gradient looks clearly the same as the earlier gradient it's not necessary to specify  $-20$  dB/decade at both the high and low frequency ends of the plot.

At some point the gradient of  $-20$  dB/decade should be marked.

The three dashed lines show the three terms in the function  $H(\omega)$ .

It is their sum that makes the main plot.

The negative sign in  $H(\omega)$  is irrelevant to our case, as this is an amplitude plot. In a phase plot, it would have caused a  $180^\circ$  phase shift.

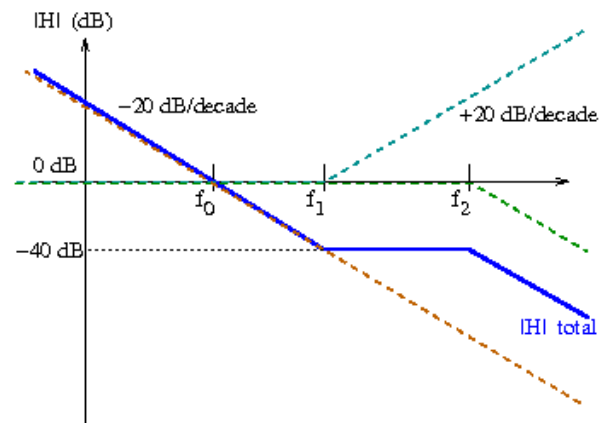

## Q8

In case the description about  $R_x$  and  $C_x$  did not seem clear, please note that there would not have been a reason to include the word “parallel” if meaning that  $R_x$  and  $C_x$  should be in series with each other: in that case, they would together have just two available terminals, and the shown circuit has just two available terminals, so there is only one non-trivial connection of these two chunks.

a. Just  $R_x$  and  $C_x$  can be varied.

The rest of the circuit has fixed component-values.

Active power to  $R_x$  is to be maximized.

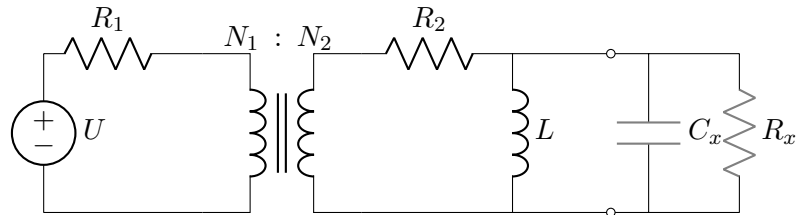

This is a very classic ac maximum power case. With  $R_x$  and  $C_x$  forming the load, we can freely control both the active and reactive parts of the load, and the reactive part of the load is the opposite type to the source. It is therefore possible to fulfil the maximum power condition  $Z_{\text{load,maxP}} = Z_{\text{source}}^*$ .

### I. A thinky, not very algebraic way.

This is a convenient case, as the reactive parts of the source and load are each in just one component, and those two components are directly connected to each other. We can therefore directly choose  $C_x$  to have the same reactance (magnitude) as  $L$ , knowing that this will cause the two components to ‘cancel’ (parallel resonance),

$$\frac{1}{\omega C_x} = \omega L \quad \implies \quad C_x = \frac{1}{\omega^2 L}.$$

Now, with equal and opposite capacitive and inductive reactances, the parallel pair form an open-circuit (zero admittance, infinite impedance), so can be ignored.

Our resistor  $R_x$  should match the resistance of the source at its terminals. We only have to consider the resistance in the source in this case, because we’ve already dealt with the inductance by cancelling it with the load capacitance. (It would not have been so easy if the inductance had been hiding on the other side of  $R_2$ , as it then would not have the same voltage as the capacitance, so the relation of  $C_x$  to  $L$  would depend on other components too.)

Transferring  $R_1$  to the right of the transformer, we get a total resistance in the source of  $\frac{N_2^2}{N_1^2} R_1 + R_2$ . This is the resistance that the load resistor should also have, for maximum power,

$$R_x = \frac{N_2^2}{N_1^2} R_1 + R_2.$$

### II. Another way.

Here, we treat the problem in a more equation-based way, working from the basic rules without thinking of simplifications for this special case.

The original circuit can be redrawn with everything referred to the secondary side, so the original  $U$  and  $R_1$  become scaled values.

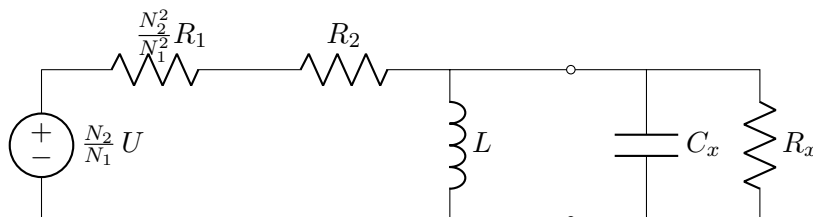

Everything on the source side of the terminals can be made into one Thevenin or Norton source, and everything on the load side can be made into one impedance. In the Norton case we’ll express the impedances in reciprocal form, admittance, where  $Y_x = 1/Z_x$ .



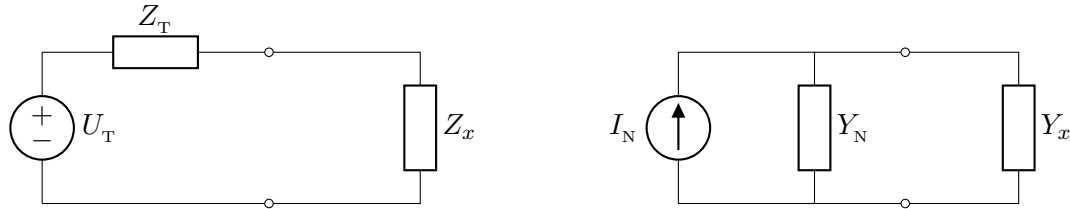

The admittance of the source, seen at the terminals, is the parallel sum of the inductor and the two series resistors.

$$Y_N = \frac{1}{Z_T} = \frac{1}{\frac{N_2^2}{N_1^2}R_1 + R_2} + \frac{1}{j\omega L} = \frac{\frac{N_2^2}{N_1^2}R_1 + R_2 + j\omega L}{\left(\frac{N_2^2}{N_1^2}R_1 + R_2\right)j\omega L}.$$

The admittance of the load is the parallel sum,

$$Y_x = \frac{1}{Z_x} = \frac{1}{R_x} + j\omega C_x.$$

The source's Thevenin voltage, i.e. the open-circuit voltage at the terminals, can be found by voltage division:

$$U_T = \frac{\frac{N_2}{N_1}U j\omega L}{\frac{N_2^2}{N_1^2}R_1 + R_2 + j\omega L}.$$

Alternatively, the source's Norton current, i.e. the short-circuit current at the terminals, can be found more easily, by Ohm's law, as no current passes in the inductor when the terminals are short-circuited,

$$I_N = \frac{\frac{N_2}{N_1}U}{\frac{N_2^2}{N_1^2}R_1 + R_2}.$$

Having bothered to find the three connected quantities,  $U_T$ ,  $I_N$  and  $Y_N$ , we can check that  $I_N/U_T = Y_N$ , which fortunately it does. For part 'a' we only need the impedance or admittance. However, the Thevenin voltage or Norton current of the source is useful for part 'b'.

Now we take the maximum-power condition,

$$Z_{\text{load}} = Z_{\text{source}}^* \implies Y_{\text{load}} = Y_{\text{source}}^*,$$

and apply it to our case,

$$Y_x = Y_N^* \implies \frac{1}{R_x} + j\omega C_x = \left( \frac{1}{\frac{N_2^2}{N_1^2}R_1 + R_2} + \frac{1}{j\omega L} \right)^* = \frac{1}{\frac{N_2^2}{N_1^2}R_1 + R_2} + j\frac{1}{\omega L}.$$

Compare separately the real and imaginary parts in the above. They show the same results for  $R_x$  and  $C_x$  as were found by the earlier method, **I**.

We chose admittance, which fits well with the parallel connection of the reactive and resistive parts in our source and load. If we worked with impedance the expressions would look rather less pleasant. If the circuit had been a series loop, it would have been more convenient to work with impedances.

**b.** In the maximum-power condition, the reactive parts of the source and load cancel. In our specific case, these parts ( $L$  and  $C_x$ ) are directly parallel connected, so they cancel independently of other components and can be ignored. What remains is just a loop with the three resistors, of which  $R_x$  has a value equal to the other two together. The current around the loop is what the Thevenin voltage pushes through the total resistance. The power it dissipates in  $R_x$  is the power we want to find, which is

$$P_{\text{max}} = \left( \frac{\frac{N_2}{N_1}U}{2\left(\frac{N_2^2}{N_1^2}R_1 + R_2\right)} \right)^2 \cdot \left( \frac{N_2^2}{N_1^2}R_1 + R_2 \right) = \frac{1}{4} \cdot \frac{U^2}{R_1 + R_2 N_1^2 / N_2^2}.$$

## Q9

a. Each primary winding (coil) of the transformer has a voltage magnitude of  $\frac{1}{\sqrt{3}}U$ . This can be seen from KVL in the loops at the left, including the neutral conductor in the loop. It can also be seen as the result of having Y-connected phases of the source and the transformer primary: these things therefore both get the same phase-voltage.

By the transformer's ratio, each secondary winding has voltage magnitude  $\frac{N_2}{N_1} \frac{1}{\sqrt{3}}U$ .

The secondary windings are  $\Delta$ -connected, so this is also the voltage between the outgoing connections to the load, i.e. the line-voltage on the secondary side of the transformer.

The load is Y-connected, so each of its phases gets  $\frac{1}{\sqrt{3}}$  of the line voltage.

Chaining the above points together,

$$|u_{R\gamma}| = \frac{1}{\sqrt{3}} \frac{N_2}{N_1} \frac{1}{\sqrt{3}} U = \frac{U N_2}{3 N_1}.$$

b. The circuit has just sources, ideal transformers and resistors. Ideal transformers simply transfer complex power, without producing or consuming. The total complex power from the three-phase source is therefore the same as the total complex power to the load resistors, which can be found by the relation  $S = |u|^2/Z^*$ .

$$S_{\text{total}} = 3 \frac{\left(\frac{U N_2}{3 N_1}\right)^2}{R^*} = \frac{U^2 N_2^2}{3 R N_1^2}.$$

c. The  $N_2/N_1$  ratio determines the ratio of magnitudes of  $u_{2c}$  and  $u_{1c}$ . As the primary is connected to a voltage source, its voltage is fixed, by KVL in the bottom left loop, to be the source voltage  $u_c$ .

$$u_{2c} = \frac{N_2}{N_1} \frac{U}{\sqrt{3}} \angle \frac{-4\pi}{3}.$$

d.  $\angle u_{R\gamma} = 90^\circ$ .

*Geometrically.*

Draw in the complex plane the phasors for the phase voltages of the source, as shown in the upper diagram. These are also the voltages on the transformer primaries.

In the lower diagram we consider what's happening in the secondary connections. The voltages on the transformer secondaries,  $u_{2(a,b,c)}$  have the same angles. The only difference is that their magnitudes are scaled by  $N_2/N_1$ , which is represented as  $n$  in the diagram on the right. The scaling is not important as it applies similarly to all phases and we only want to find the angle.

Let's start from the lower end of the top-transformer's secondary. We can choose an arbitrary point in the complex plane to represent the potential of this node in the circuit. Starting from this potential we draw the voltage  $u_{2a}$ , with the same direction as was drawn for the primary voltage  $u_{1a}$ . The far end of this line is the potential at the top (dot-end) of the top transformer's secondary. This top node connects down to the lower end of the bottom transformer's secondary, so we now draw the voltage  $u_{2c}$  to find the potential of the point at the dot-end of the bottom transformer. From there, we draw the remaining voltage,  $u_{2b}$ , which takes us back to the starting point again.

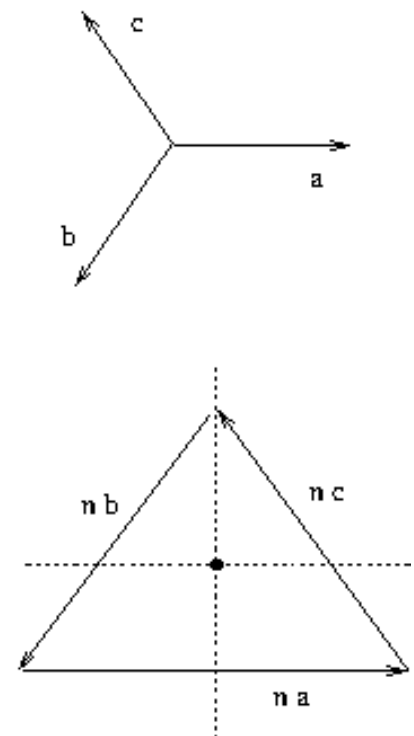

Now we have the potentials at the transformer output (secondary terminals), using an arbitrary reference.

All we care about is the voltage  $u_{R\gamma}$ , which is between one of the transformer output potentials and the load's neutral point. It is not affected by our choice of reference.

The load resistors have a balanced Y connection, so their neutral point's potential will be the mean of the three potentials of the transformer output. The neutral potential is therefore the centre point of the triangle of phasors that we drew.

The + end of voltage  $u_{R\gamma}$  connects to the node between the lower and middle transformers. In our phasor diagram, the potential of this node is the point between lines c and b, which is the top corner of the triangle. Relative to the centre point of the triangle, this potential lies along the +j direction in the complex plane.

Thus,  $\angle \underline{u_{R\gamma}} = \pi/2$ .