

Permitted material: Beyond writing-equipment, up to three pieces of paper up to A4 size can be used, with free choice of content: handwritten, printed; small, large; text, diagram, image; one or both sides, etc. These papers do not need to be handed in with the exam.

Unless it is stated otherwise, the final answer to a question should be expressed in terms of the known quantities given in the question, and any clear simplifications should be done. Component values such as R for a resistor, U for an independent voltage source, or K for a dependent source, are assumed to be known quantities. Marked currents or voltages such as i_x are assumed to be definitions, not known quantities.

Clearly drawn and labelled diagrams are a good way to help yourself avoid mistakes, and to make clear to others what you are doing. By showing clearly your intermediate steps in a solution, you improve your chance of getting points even if the final result is wrong. You may write in Swedish or English; but we suggest that writing in either is seldom necessary if you make good use of diagrams and equations!

Determination of exam grade. Let A , B and C be the available points from sections A, B and C of this exam: $A=12$, $B=10$, $C=18$. Let h be the homework ‘bonus’, and a , b and c be the points obtained in the respective sections, where each question’s points are the highest obtained at any opportunity during this course-round, i.e. exam in March, exam in June, mini-exams (KS) in February, or the project task that can substitute for question 9. The requirement for passing the exam (E or higher) is then:

$$\frac{a}{A} \geq 40\% \quad \& \quad \frac{b}{B} \geq 40\% \quad \& \quad \frac{c}{C} \geq 40\% \quad \& \quad \frac{a+b+c+h}{A+B+C} \geq 50\%$$

The grade is then determined by the total including bonus, i.e. the last of the terms above: boundaries (%) are 50 (E), 60 (D), 70 (C), 80 (B), 90 (A). If the exam misses a pass by a small margin on just one criterion, a grade of Fx may be registered, with the possibility of completing to E by an extra task arranged later.

Special for the VT21 round, both for ordinarie- and omtenta.

The exam is conducted remotely, monitored in a video meeting.

Answers must be in handwriting: either on paper that is scanned or photographed, or by handwriting into a computer by means of a suitable touchscreen or pad.

Nathaniel Taylor (08 790 6222)

Section A. Direct Current

1) [4p]

Determine:

- a) [1p] the power from source U_3
- b) [1p] the marked voltage u_x
- c) [1p] the marked voltage u_y
- d) [1p] the power from source I_2

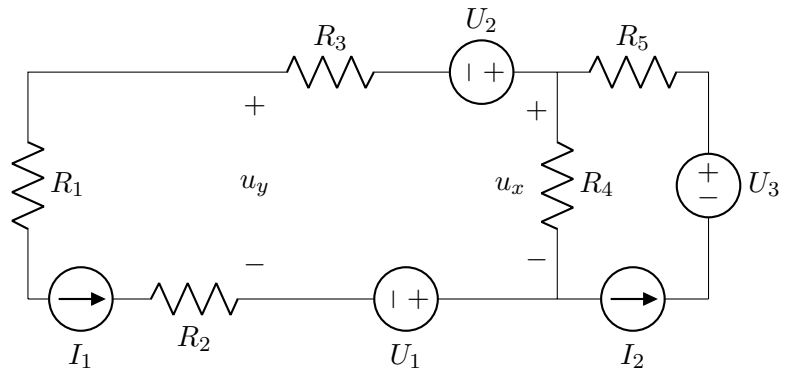

2) [4p]

Write equations that could be solved without further information to find the potentials v_1, v_2, v_3 and v_4 in this circuit in terms of the component values.

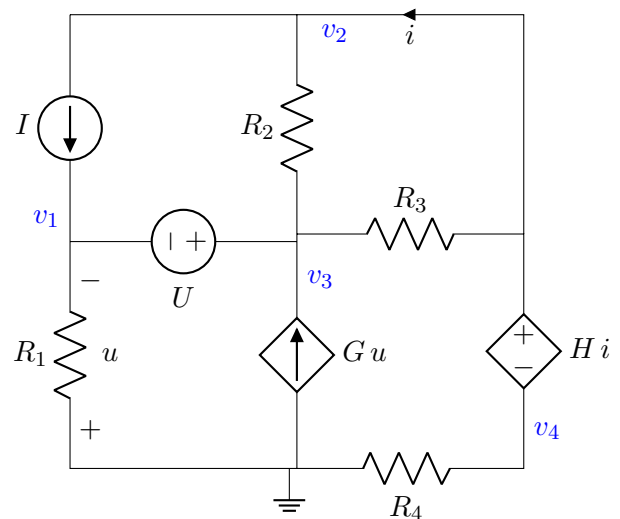

3) [4p]

a) [2p] Draw the Thevenin equivalent of this circuit, with respect to terminals a and b . Express the Thevenin voltage and resistance in terms of the original circuit's component values.

In the following parts, 'b' and 'c', assume that:

$$R_1 = R_2 = R \quad \text{and} \quad I_1 = I_2 = I.$$

Express your answers in terms of R and I .

b) [1p] What is the maximum power that this circuit can deliver at its terminals a and b .

c) [1p] Draw the Norton equivalent of the circuit, expressing its components in terms of R and I .

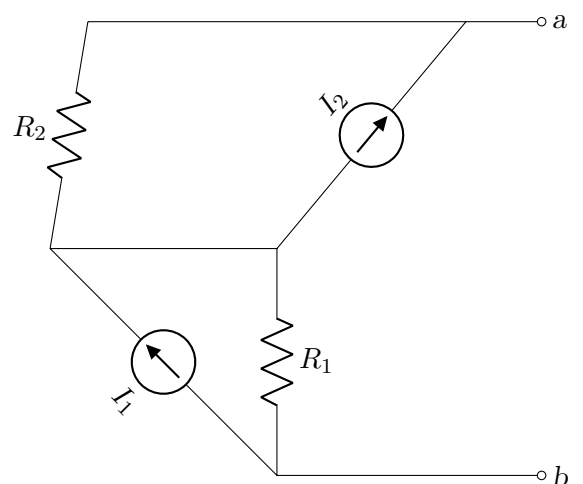

Section B. Transient Calculations

4) [5p]

Notice that *two* changes happen at $t = 0$.

Determine the:

- a) [1p] energy stored in L_1 at $t = 0^-$
- b) [2p] power into R_2 at $t = 0^+$
- c) [1p] power out of source I at $t = 0^+$
- d) [1p] energy stored in C_2 as $t \rightarrow \infty$

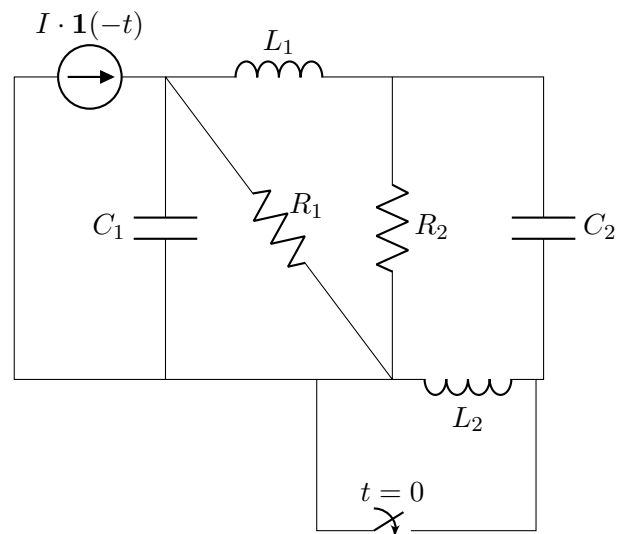

x) [0p] this is not a proper question that gives points, so you do not need to answer it – it is for interest or for future years of students: What energy is stored in L_2 as $t \rightarrow \infty$, and how would you prove this?

5) [5p]

- a) [4p] Determine $i(t)$ for $t > 0$.
- b) [1p] Determine the power into the inductor for $t > 0$.
Note: this is relatively high work for the available points.

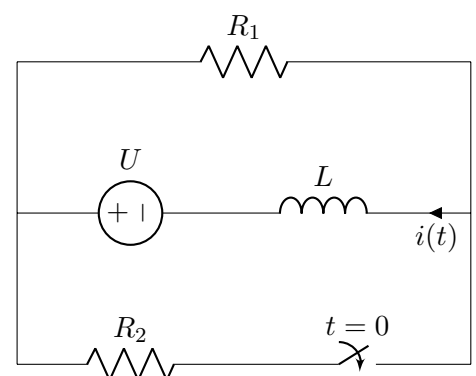

Section C. Alternating Current

6) [4p]

a) [3p] Determine $i(t)$.

b) [1p] Given the conditions

$$\omega = R/L \quad \text{and} \quad \hat{U} = \hat{I}R\sqrt{2},$$

determine $i(t)$ simplified as much as possible.

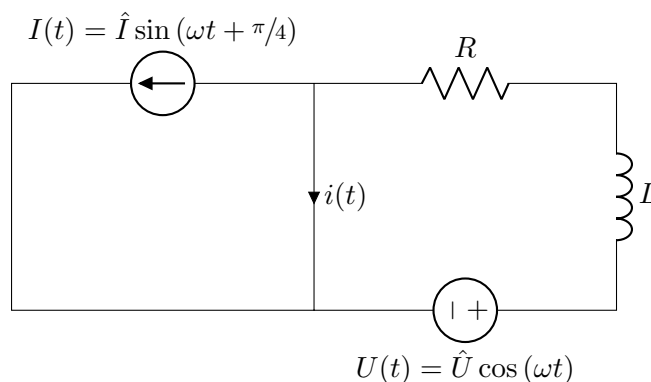

7) [4p]

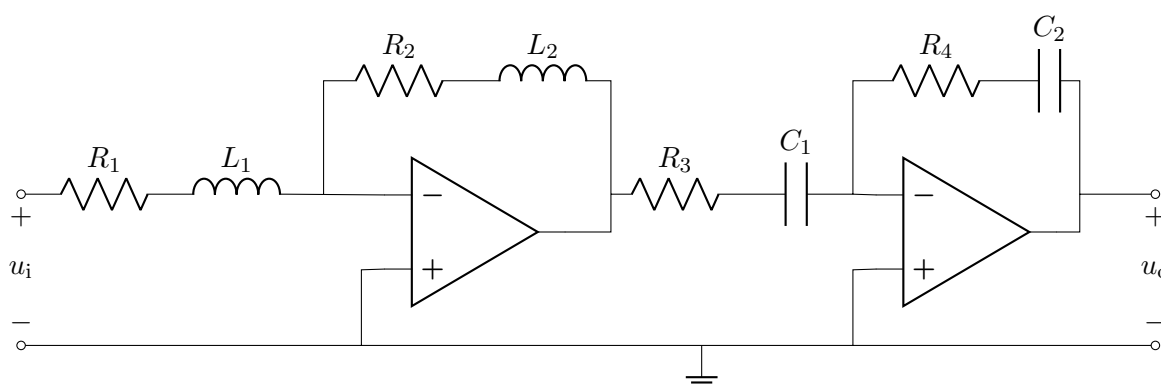

a) [2p] Find this circuit's network function, $H(\omega) = u_o/u_i$.

Hint: the solution can be done as two independent parts, so this is not as hard as it might look.

When simplified, $H(\omega)$ should have the same form as the function in part 'b'. Most of the credit here in part 'a' can be gained from a correct function even without the full simplification.

b) [2p] Sketch a Bode amplitude plot of:

$$H(\omega) = K \frac{(1 + j\omega/\omega_a)(1 + j\omega/\omega_d)}{(1 + j\omega/\omega_b)(1 + j\omega/\omega_c)}$$

Take: $K = 1$, $100\omega_a = \omega_b$, $\omega_b \ll \omega_c$, $100\omega_c = \omega_d$.

Mark significant levels and gradients.

8) [4p]

The source has angular frequency ω .

a) [3p] What values of R_2 and C will maximize the power going into R_2 ? Express these in terms of other components' values.

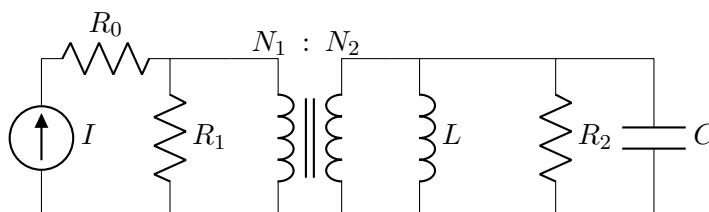

b) [1p] With R_2 and C chosen as requested in 'a', what power is transferred into R_2 ?

9) [6p]

The diagram below shows a balanced three-phase system. A three-phase voltage source supplies the primary side of a transformer that is formed from three single-phase transformers, all with $N_1 : N_2$ ratio. A resistive load is connected to the secondary side.

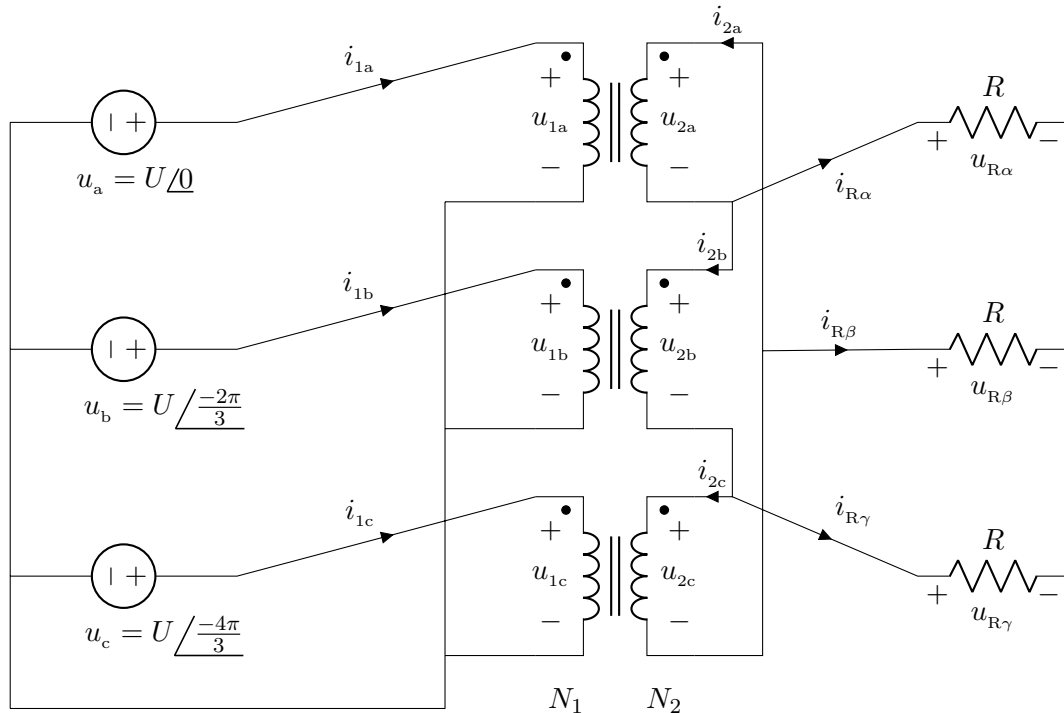

Note that straight lines crossing each other in this diagram do *not* indicate a connection. Connections here involve three lines stopping at a single point.

- [1p] What is the magnitude of the voltage u_{2b} ?
- [2p] What is the magnitude of the current $i_{R\gamma}$?
- [2p] What total power is supplied from the source (all three single-phase sources).
- [1p] What is the angle of i_{1b} ?

The End.

Please don't waste remaining time ... check your solutions!

Översättningar:

Hjälpmedel: Upp till tre A4-ark (båda sidor) med studentens egna anteckningar på valfritt sätt: handskrivet eller datorutskrift; text, diagram, bild; stor eller liten textstorlek, o.s.v. Dessa måste inte lämnas in med skrivningarna.

Om inte annan information anges i ett tal ska: komponenter antas vara ideala; angivna värden av komponenter (t.ex. R för ett motstånd, U för en spänningskälla, K för en beroende källa) antas vara *kända* storheter; och andra markerade storheter (t.ex. strömmen markerad i ett motstånd eller spänningskälla) antas vara *okända* storheter. Lösningar ska uttryckas i kända storheter och förenklas.

Var tydlig med diagram och definitioner av variabler. Du får skriva på svenska eller engelska, men vi rekommenderar att diagram och ekvationer används i stället i de flesta fall.

1. [4p] Bestäm följande:

- [1p] effekten från källan U_3
- [1p] den markerade spänningen u_x
- [1p] den markerade spänningen u_y
- [1p] effekten från källan I_2

2. [4p] Skriv ekvationer som skulle *kunna* lösas, utan vidare information, för att bestämma potentialerna v_1 , v_2 , v_3 och v_4 , som funktioner av kretsens komponentvärden. Det rekommenderas inte att du försöker lösa ekvationerna!

3. [4p] Bestäm:

a) [2p] Theveninekvivalenten mellan polerna a och b: rit diagram.

I deltal b och c antas $R_1 = R_2 = R$ och $I_1 = I_2 = I$, och R och I används i lösningarna.

- [1p] Den maximaleffekten som källan kan leverera mellan polerna a och b
- [1p] Nortonekvivalenten mellan polerna a och b: rit diagram.

4. [5p] Bestäm:

- [1p] energin lagrad i L_1 vid $t = 0^-$
- [1p] effekten in till R_2 vid $t = 0^+$
- [2p] effekten från källan I vid $t = 0^+$
- [1p] energin lagrad i C_2 vid $t \rightarrow \infty$.

5. [5p] Bestäm, för $t > 0$:

- [4p] strömmen $i(t)$ i spolen
- [1p] effekten in till spolen.

6. [4p] Bestäm (genom växelströmsanalys):

- [3p] strömmen $i(t)$
- [1p] strömmen $i(t)$ förenklad med villkoren $\omega = R/L$ och $\hat{U} = \hat{I}R\sqrt{2}$.

7. [4p]

a) [2p] Bestäm kretsens nätverksfunktion.

b) [2p] Skissa ett Bodeamplituddiagram av $H(\omega) = K (1 + j\omega/\omega_a) (1 + j\omega/\omega_d) / [(1 + j\omega/\omega_b) (1 + j\omega/\omega_c)]$.

Anta att: $K = 1$, $100\omega_a = \omega_b$, $\omega_b \ll \omega_c$, $100\omega_c = \omega_d$.

Markera viktiga punkter och lutningar.

8. [4p] Källan har vinkelfrekvens ω .

- [3p] Vilka värden ska R_2 och C ha, uttryckt i andra komponenters värden, för att maximera effekten som kommer till R_2 ?
- [1p] Hur mycket effect (aktiveffekt) kommer till R_2 när R_2 och C väljs enligt 'a'?

9. [6p]

- [1p] Magnituden av spänning u_{2b}
- [2p] Magnituden av strömmen $i_{R\gamma}$
- [2p] Totaleffekten levererad av källan (alla tre enfasiga källorna tillsammans)
- [1p] Vinkeln av strömmen i_{1b} .

Solutions (EI1120 TEN1 VT21, 2021-06-10)

Q1

a. $P_{U_3} = U_3 I_2$

Two find the power in or out of any two-terminal ‘thing’ (component, or bigger part of a circuit) we just need to multiply its terminal voltage and current, using the correct sign for the directions in which these are defined and the direction of power that we want.

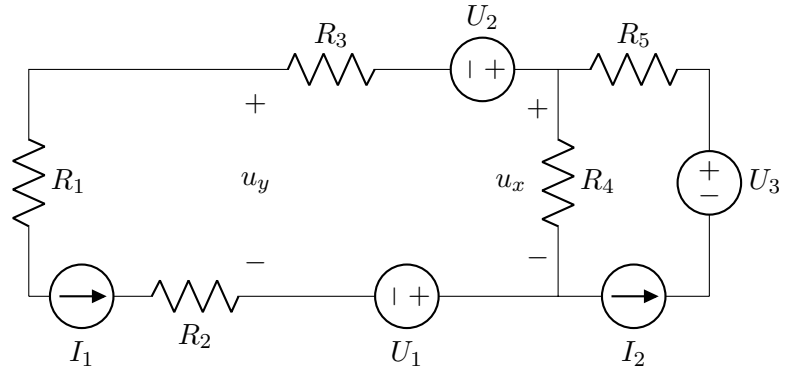

Source I_2 with KCL already determines the current up through U_3 . Source U_3 determines its own voltage. The product of voltage with current out of the voltage’s + terminal (‘active convention’) is the power out of the component.

b. $u_x = (I_2 - I_1) R_4$

The loops to the left and right of R_4 both have their current fixed by a current source. By KCL below or above R_4 , the current down R_4 is $I_2 - I_1$. Ohm’s law then gives u_x . Be careful to get the sign right: if the current going *up* R_4 had been found, a minus sign would be needed in Ohm’s law to find the voltage marked in the direction that u_x is.

c. $u_y = I_2 R_4 + U_1 - U_2 - I_1 (R_3 + R_4)$

Take KCL around the loop of u_y , R_3 , U_2 , R_4 , U_1 .

(This perhaps doesn’t look like a ‘loop’ in the circuit. Then consider u_y as a component that just happens to be an open circuit, zero current-source or whatever. Or think ‘potentialvandring’ [Swedish for ‘hiking through potential-changes’?] instead of strict loop-based KVL.)

We already have found u_x . The voltage across R_3 is known through Ohm’s law as the source I_1 fixes the branch’s current. The voltage sources have given values. Thus $u_y = U_1 + u_x - U_2 - I_1 R_3$. Substitute u_x from part ‘b’, and perhaps regroup for neatness.

The main trick in this question is that you *shouldn’t* do KVL around the leftmost loop as the current source has an unknown voltage, not necessarily zero.

d. $P_{I_2} = I_2^2 (R_4 + R_5) - I_1 I_2 R_4 - U_3 I_2$.

Again, KVL around a loop, this time to find the voltage across source I_2 . Then multiply by the source current. We’ll define the voltage across I_2 with its reference (+) side on the right. KVL gives it as $(I_2 - I_1) R_4 + I_2 R_5 - U_3$.

Q2

Extended nodal analysis

First, write KCL at every node except the reference (earth) node.

In order to handle the voltage sources, we define their unknown currents. Here we have defined i_α in the independent voltage source U , and i_β in the dependent voltage source $H i$, both going in to the source's + terminal.

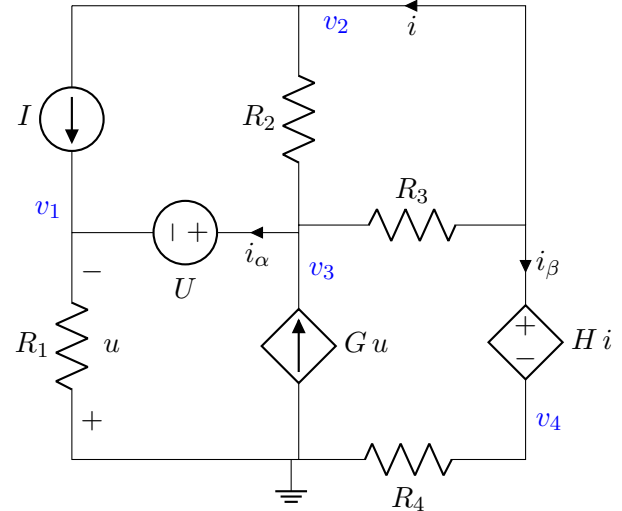

$$\text{KCL(1)}_{(\text{out})} : 0 = \frac{v_1}{R_1} - i_\alpha - I \quad (1)$$

$$\text{KCL(2)}_{(\text{out})} : 0 = I + \frac{v_2 - v_3}{R_2} + \frac{v_2 - v_3}{R_3} + i_\beta \quad (2)$$

$$\text{KCL(3)}_{(\text{out})} : 0 = -G u + i_\alpha + \frac{v_3 - v_2}{R_2} + \frac{v_3 - v_2}{R_3} \quad (3)$$

$$\text{KCL(4)}_{(\text{out})} : 0 = \frac{v_4}{R_4} - i_\beta \quad (4)$$

Then write the extra information that the voltage sources give about the node potentials:

$$v_3 - v_1 = U \quad (5)$$

$$v_2 - v_4 = H i \quad (6)$$

Finally, express the definitions of the marked quantities that control dependent sources:

$$u = -v_1 \quad (7)$$

$$i = I + \frac{v_2 - v_3}{R_2} \quad (8)$$

The current i is marked within part of a node: it is not the current in any single component. We chose to define it in terms of the currents leaving the node where the current-arrow points. We could equally well have defined it in terms of the current entering the node in components on the other side of the arrow, i.e. the current in R_3 and the current i_β in the dependent voltage source. As we already have KCL(2), either of the expressions for i can be derived from the other expression for i and KCL(2).

The above are 8 equations in 8 unknowns: $v_1, v_2, v_3, v_4, i_\alpha, i_\beta, u, i$. Having followed the rules, we expect them to be independent equations.

Q3

The circuit between terminals a and b can be seen as a series connection of two Norton sources.

Its open circuit voltage must be $I_1 R_1 + I_2 R_2$, for node a relative to node b . This can be seen by KCL at the top and bottom when no current flows in the terminals, and then KVL through the two resistors.

Its equivalent resistance is simply $R_1 + R_2$. It is a dc circuit with no dependent sources, so there are only resistors remaining if we set all the independent sources to zero, i.e. make the current-sources open circuit.

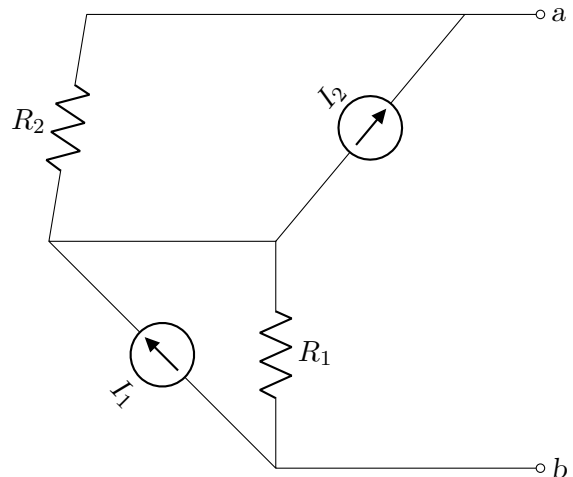

a. The Thevenin parameters were shown in the above text. For this part of the answer there should be a diagram, and it should show the series-connected voltage source and resistor with correct values, and the terminals a and b should be marked to show the correct direction of the Thevenin voltage.

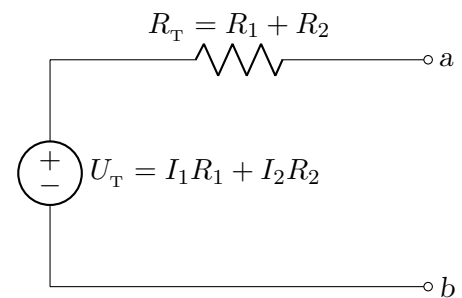

b. Maximum power from a Thevenin source is:

$$\frac{U_T^2}{4R_T} = \frac{(I_1 R_1 + I_2 R_2)^2}{4(R_1 + R_2)}.$$

If we use the given simplification of $I_1 = I_2 = I$ and $R_1 = R_2 = R$, then:

$$P_{\max} = \frac{(2IR)^2}{4(2R)} = \frac{1}{2} I^2 R.$$

c. The Norton resistance is the same as the Thevenin resistance. In contrast to part 'a' we can here use the simplification such that $R_1 + R_2$ becomes $2R$.

The Norton current is $I_N = U_T / R_T$. After putting in the simplifications as in part 'b', this becomes

$$I_N = \frac{2IR}{2R} = I.$$

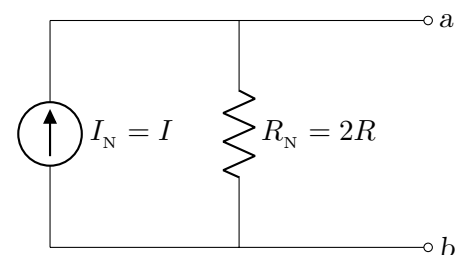

The relation $I_N = I$ can alternatively be seen simply by considering the original circuit short-circuited, with identical sources and resistors. The equal values of the current sources mean that there is no unbalanced current to flow through either resistor. The terminal current is therefore the same as each source's current.

Q4

The original circuit is shown on the right.

Two changes happen, both at time $t = 0$: the current source ‘turns off’, and the switch closes.

We have to solve for quantities in the initial equilibrium (0^-), final equilibrium (∞), and just after the disturbance of the initial equilibrium (0^+).

For each state we’ll draw a simplified diagram.

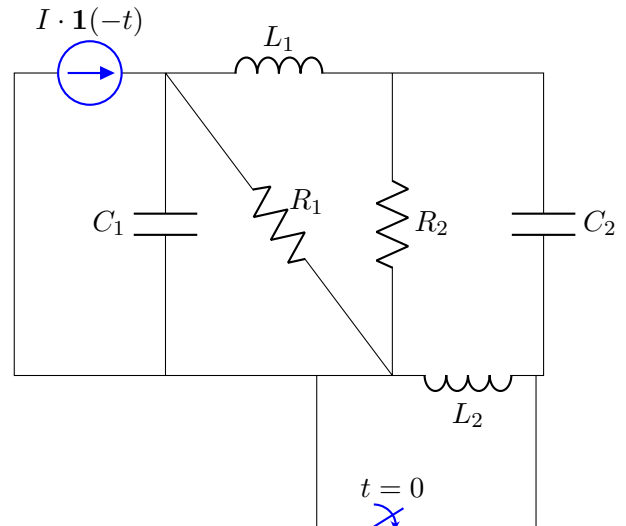

INITIAL EQUILIBRIUM, $t = 0^-$.

At this time the switch is still open, so its whole branch has been removed.

The current source is active, as the unit-step function with negated time, $\mathbf{1}(-t)$, is 1 for $t < 0$. This source value is therefore written as just I for this specific time-range.

The assumption of equilibrium, i.e. constant values of all voltages and currents, implies that inductors behave as short-circuits and capacitors as open-circuits.

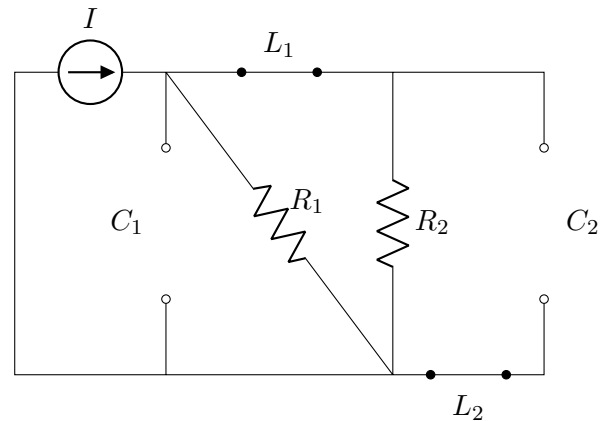

By current division the current through L_1 is $\frac{IR_1}{R_1+R_2}$. From this the stored energy in L_1 can be determined.

a.
$$W_{L_1}(0^-) = \frac{1}{2}L_1 \left(\frac{IR_1}{R_1 + R_2} \right)^2.$$

CONTINUITY JUST AFTER THE STEP, $t = 0^+$.

Here, the capacitor voltages and inductor currents have not had a chance to change in spite of the voltage-source’s change. We can represent them as sources, as shown on the right. The values of these sources can be found from the case at $t = 0^-$.

We already have already found i_{L_1} at $t = 0^-$.

By continuity, $i_{L_1}(0^+) = \frac{IR_1}{R_1+R_2}$.

By continuity the capacitors still have the same voltage as at $t = 0^-$. At $t = 0^-$, the voltage across R_1 and R_2 is caused by the source current I passing through their parallel sum. By KVL at $t = 0^-$ this is also the voltage across the capacitors.

Hence $u_{C_1}(0^+) = u_{C_2}(0^+) = I \frac{R_1 R_2}{R_1 + R_2}$.

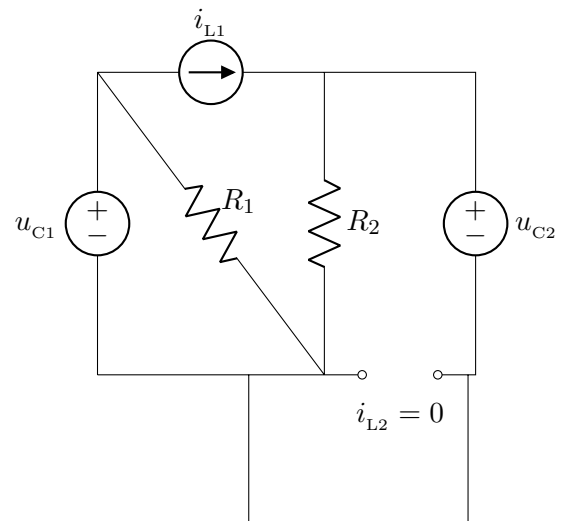

In the circuit at $t = 0^+$, KVL gives the voltage across R_2 as u_{C_2} .

b.
$$P_{R_2}(0^+) = \frac{u_{C_2}^2}{R_2} = \frac{I^2 R_1^2 R_2}{(R_1 + R_2)^2}.$$

The source's current is 0 at $t = 0^+$, as the step function (with time negated) is zero then. So there cannot be any power into or out of the source.

c. $P_1(0^+) = 0.$

FINAL EQUILIBRIUM, $t \rightarrow \infty$.

The energy stored in C_2 is zero, as the circuit has stood for 'a long time' (equilibrium) with no source driving it and with resistors connected across C_2 . With no current in the resistors, there cannot be voltage across the capacitor.

The initial stored energy in inductors and capacitors ($t = 0^+$) will decay if it is used to push current in the resistors.

d. $W_{C_2}(\infty) = 0.$

The following answer was probably found by anyone who looked at this non-rewarding part-question!

x. $W_{L_2}(\infty) = 0.$

This is correct: but how can one prove it?

It may be tempting to use the diagram on the right, claiming equilibrium and the lack of any source: in other words, the same idea as in Q4d. But there is a difference. In Q4d we could argue that there can only be a voltage on the capacitor (after a long time) if something can *keep* supplying power to the resistors that are in parallel with it ... and there is no source to do this.

Here, instead, the inductor L_2 is short-circuited for all $t > 0$, so it has zero voltage. Zero voltage on a component means it can't have power in or out, so its stored energy remains. Alternatively we could see this as $u = 0 \implies \frac{di}{dt} = 0$ for an inductor. So its current must be the same at $t \rightarrow \infty$ as at $t = 0^+$, or (by continuity) at $t = 0^-$.

Looking back to the circuit at the equilibrium of $t = 0^-$ the inductor is in series with a capacitor, so its current is zero. This is the argument that is needed to justify the tempting and correct answer of 0.

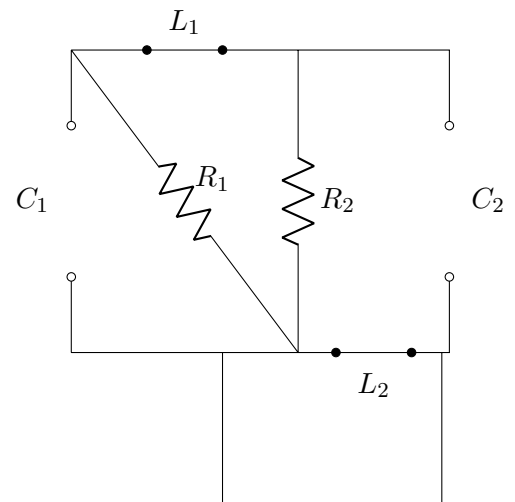

Q5

a. The marked current $i(t)$ is the current in the inductor, so it is a continuous quantity.

Its value at $t = 0^+$ (the start of the period of interest) is the same as its value at $t = 0^-$ (just before the switch closes).

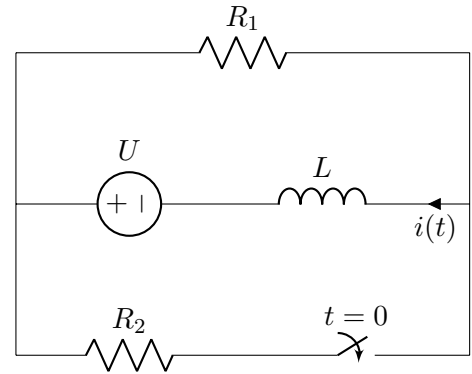

At $t = 0^-$ the branch with the switch is open.

The inductor is in equilibrium (zero voltage) as the circuit has had no recent changes.

By KVL around the single remaining loop,

$$i(0^-) = \frac{U}{R_1}.$$

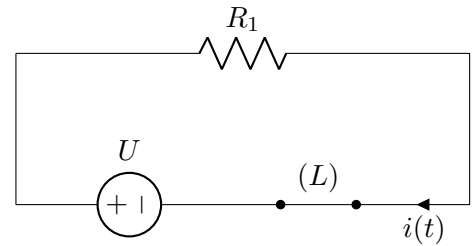

The period of interest is $t > 0$, from the time when the switch closes.

R_2 is then in parallel with R_1 .

This can be drawn in simplified form as on the right. It is directly a Thevenin source connected to the inductor.

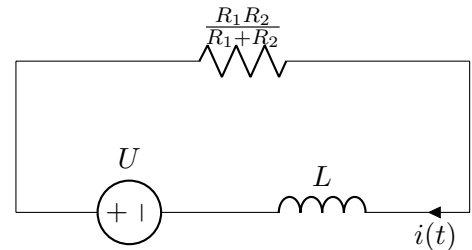

Taking KVL around the loop,

$$U - \frac{R_1 R_2}{R_1 + R_2} i - L \frac{di}{dt} = 0,$$

from which

$$\frac{di}{dt} + \frac{R_1 R_2}{R_1 + R_2} \frac{1}{L} i = \frac{1}{L} U.$$

This (by a standard result for this form of ODE, $y' + ay = b$) has the solution

$$i(t) = \frac{\frac{1}{L} U}{\frac{R_1 R_2}{R_1 + R_2} \frac{1}{L}} + A e^{-t \frac{R_1 R_2}{L(R_1 + R_2)}} = \frac{U (R_1 + R_2)}{R_1 R_2} + A e^{-t \frac{R_1 R_2}{L(R_1 + R_2)}}.$$

The constant A can be found from the initial condition,

$$i(0^+) = i(0^-) = \frac{U}{R_1} = \frac{U (R_1 + R_2)}{R_1 R_2} + A \quad (\text{as } e^0 = 1),$$

giving that

$$A = \frac{U}{R_1} - \frac{U (R_1 + R_2)}{R_1 R_2} = \frac{-U}{R_2}.$$

Therefore,

$$i(t) = \frac{U (R_1 + R_2)}{R_1 R_2} - \frac{U}{R_2} e^{-t \frac{R_1 R_2}{L(R_1 + R_2)}} \quad (t > 0).$$

b. The power into the inductor is the product of its current and voltage, with suitable choice of sign. If we define the inductor's voltage as u with its reference side (+) where the current i goes in, then from the relation of inductor current and voltage,

$$u(t) = L \frac{di(t)}{dt} = L \cdot \frac{-U}{R_2} \cdot \frac{-R_1 R_2}{L(R_1 + R_2)} \cdot e^{-t \frac{R_1 R_2}{L(R_1 + R_2)}}.$$

The power is then

$$p(t) = u(t) \cdot i(t) = \frac{UR_1}{R_1 + R_2} e^{-t \frac{R_1 R_2}{L(R_1 + R_2)}} \left(\frac{U(R_1 + R_2)}{R_1 R_2} - \frac{U}{R_2} e^{-t \frac{R_1 R_2}{L(R_1 + R_2)}} \right).$$

This is not made much simpler by rearranging, so there's no requirement to do more than the above.

One might like to collect it as two terms, to show that it's two decaying exponentials, with different speeds and directions:

$$p(t) = \frac{U^2}{R_2} \left(e^{-t \frac{R_1 R_2}{L(R_1 + R_2)}} - \frac{R_1}{R_1 + R_2} e^{-2t \frac{R_1 R_2}{L(R_1 + R_2)}} \right) \quad (t > 0).$$

Q6

a. Determine $i(t)$.

Both sources have the same frequency (angular frequency ω) so we can use a single ac analysis.

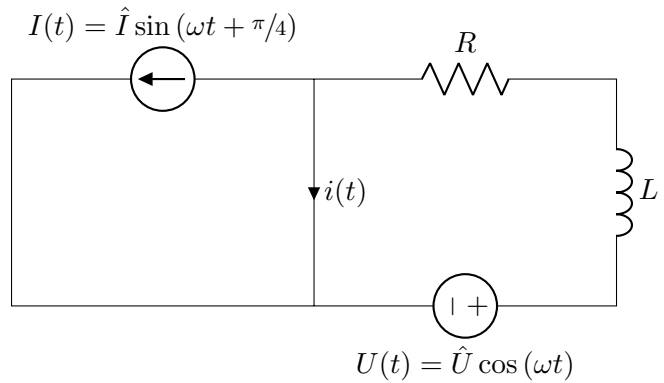

Start by defining the circuit as phasors and impedances instead of time functions.

We'll use a cosine reference and peak values.

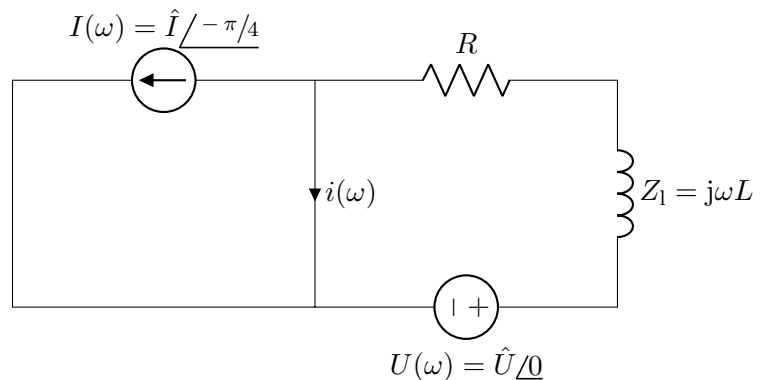

The marked current i can be found by KCL from the currents in the left and right branches.

The current in the left branch is already defined by the function given for the current source.

The current in the right branch can be found by the source voltage and KVL in the right loop. Defined in the upward direction in the right branch, this is $\frac{U(\omega)}{R + j\omega L}$.

Putting these together by KCL,

$$i(\omega) = \frac{U(\omega)}{R + j\omega L} - I(\omega) = \frac{\hat{U} / 0}{R + j\omega L} - \hat{I} / -\pi/4.$$

In order to find the time-function of this solution, we use the same choice of reference angle and magnitude as when we converted from the original time-functions. In our case, with cosine reference and peak values, we can write the time-function as

$$i(t) = |u(\omega)| \cos(\omega t + \angle u(\omega)).$$

In order to do this, the magnitude and angle of $i(\omega)$ must be found. The expression for $i(\omega)$ has two terms that are added (here, we're using 'adding' broadly, to mean adding or subtracting). It is not a good idea to make these terms into polar form before they are added. Adding is much neater in rectangular form. So we make each term into a separate real and imaginary part:

$$i(\omega) = \frac{\hat{U}}{R^2 + \omega^2 L^2} (R - j\omega L) - \hat{I} \left(\frac{1}{\sqrt{2}} - \frac{j}{\sqrt{2}} \right)$$

The factors with $1/\sqrt{2}$ in the above come from taking \cos and \sin of the $-\pi/4$ angle.

Now group the real and imaginary parts together, to get a neat rectangular form,

$$i(\omega) = \left(\frac{\hat{U}R}{R^2 + \omega^2 L^2} - \frac{\hat{I}}{\sqrt{2}} \right) + j \left(\frac{\hat{I}}{\sqrt{2}} - \frac{\hat{U}\omega L}{R^2 + \omega^2 L^2} \right).$$

In order to avoid writing out the above expressions several times, let's write the above as $i(\omega) = a + jb$, and express the time-function as:

$$i(t) = \sqrt{a^2 + b^2} \cos(\omega t + \arctan b/a).$$

In this case, where the terms don't simplify nicely when finding the magnitude and angle, it is fine to write the solution in the above short way. It shows adequately that one knows the steps. (But if an appreciable simplification could be made after putting in the full expressions in the solution, then that path should be followed.)

b. Simplify $i(t)$ given the conditions:

$$\omega = R/L \quad \text{and} \quad \hat{U} = \hat{I}R\sqrt{2}.$$

Consider the final expression for $i(\omega)$ in part 'a'.

The first condition means that the terms involving \hat{U} have equal magnitude in the real and imaginary parts, since $\omega L = R$.

The second condition means that each term with \hat{U} has the same magnitude but opposite sign, to the corresponding term with \hat{I} .

For example, if we substitute both conditions into one of the \hat{U} terms, we get

$$\frac{\hat{U}R}{R^2 + \omega^2 L^2} = \frac{\hat{U}R}{R^2 + R^2} = \frac{\hat{U}}{2R} = \frac{\hat{I}R\sqrt{2}}{2R} = \frac{\hat{I}}{\sqrt{2}}.$$

The fully simplified result is then

$$i(\omega) = 0, \quad i(t) = 0.$$

Q7

- a. This is two inverting amplifiers, cascaded.
Each has two components making up each of its impedances.

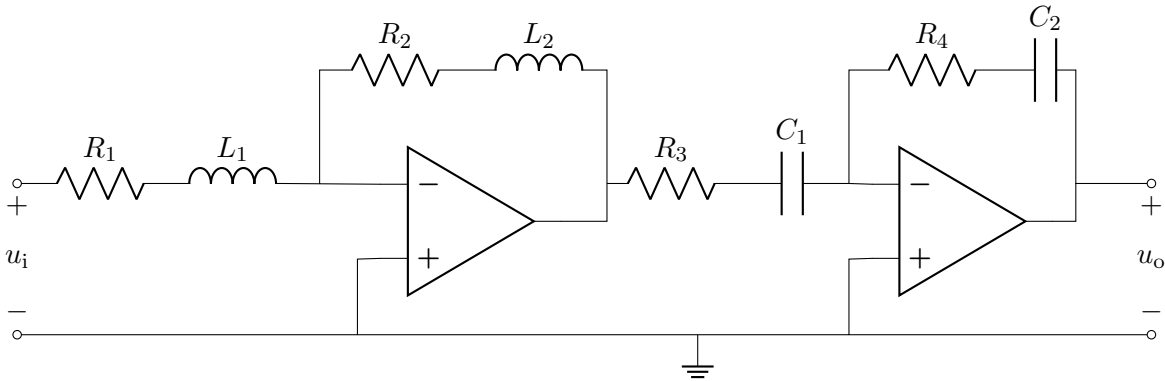

The input to the second amplifier (the left side of R_3) connects to the first amplifier's opamp output. This is a stiff voltage source, which the left opamp forces to be whatever potential is needed to ensure that its inverting input stays at its inverting input's zero potential. So this is not affected by whatever current flows through R_3 . The two amplifiers can therefore be analysed separately, and their network functions combined to give the total network function.

In the first amplifier, the feedback impedance is $Z_2 = R_2 + j\omega L_2$ and the input impedance is $Z_1 = R_1 + j\omega L_1$. Its network function is then $H_1 = -Z_2/Z_1$, from the standard result for an inverting amplifier.

Doing similarly for the second amplifier, and putting the two together,

$$H(\omega) = H_1(\omega) \cdot H_2(\omega) = \frac{-(R_2 + j\omega L_2)}{R_1 + j\omega L_1} \cdot \frac{-(R_4 + \frac{1}{j\omega C_2})}{R_3 + \frac{1}{j\omega C_1}}$$

Now divide or multiply terms by suitable factors to get the standard form of $1 + j\omega/\omega_x$,

$$H(\omega) = \frac{R_2 + j\omega L_2}{R_1 + j\omega L_1} \cdot \frac{R_4 + \frac{1}{j\omega C_2}}{R_3 + \frac{1}{j\omega C_1}} = \frac{R_2 C_1}{R_1 C_2} \cdot \frac{1 + j\omega L_2/R_2}{1 + j\omega L_1/R_1} \cdot \frac{1 + j\omega C_2 R_4}{1 + j\omega C_1 R_3}$$

b. Bode amplitude plot of

$$H(\omega) = K \frac{(1 + j\omega/\omega_a)(1 + j\omega/\omega_d)}{(1 + j\omega/\omega_b)(1 + j\omega/\omega_c)},$$

given that $K = 1$, $100\omega_a = \omega_b$, $\omega_b \ll \omega_c$, $100\omega_c = \omega_d$.

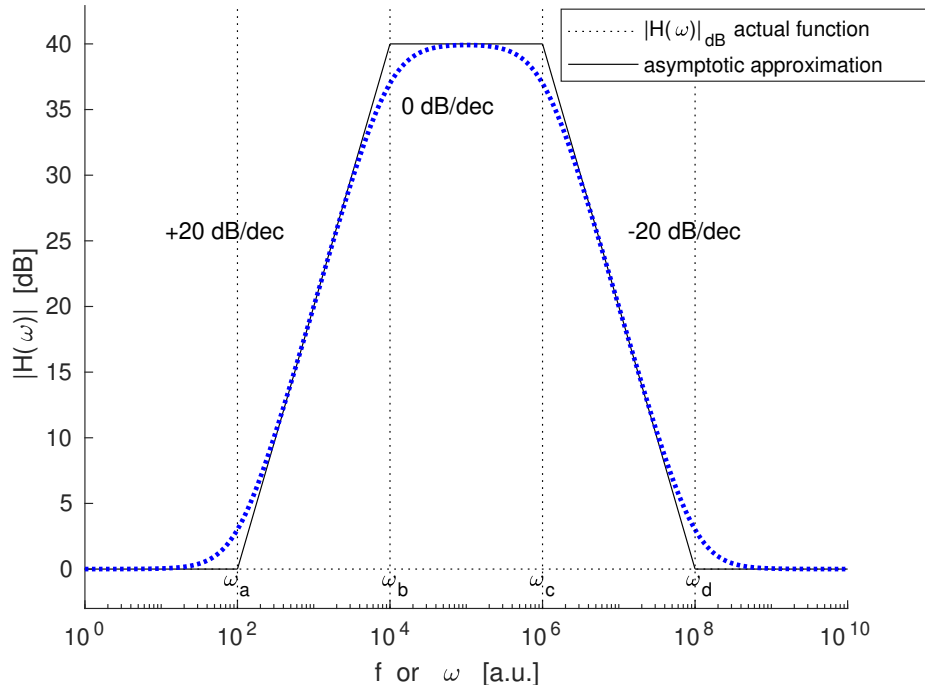

Necessary parts are: the asymptotic approximation lines, the gradients of the up and down slopes, the 0 dB and 40 dB levels, and the locations of $\omega_{a,b,c,d}$. The actual curve is not needed. The flat parts do not need marking with 0 dB/decade. No numeric frequencies are needed.

Some explanation of the plot:

For $\omega \ll \omega_a$, all the five multiplied or divided terms are 1, so the amplitude is $|H(\omega)| = 1$, i.e. 0 dB.

When ω exceeds ω_a , the term $(1 + j\omega/\omega_a)$ gives a magnitude that rises at 20 dB/decade.

When ω exceeds ω_b , the term on the bottom contributes with -20 dB/decade to $|H(\omega)|$, so it cancels the contribution from the ω_a term and the plot stays flat at 40 dB.

Because $\omega_b = 100\omega_a$, the rising amplitude between ω_a and ω_b continues for 2 decades. The magnitude at the top, $|H(\omega_b)|$, is therefore +40 dB, as we know it started from zero and rose at 20 dB/decade for 2 decades.

When ω exceeds ω_c , there is a further downward-going term at -20 dB/decade.

When ω exceeds ω_d , the final term cancels the ω_c term, and no further change happens. The final level (for all $\omega > \omega_d$) is 0 dB, because the downward-going change started from 40 dB and continued for 2 decades.

Q8

a. We want to maximize the power transferred to R_2 , by adjusting R_2 and C in terms of the other component values (which are all fixed).

If we consider R_2 and C as a load impedance that we choose, and the rest of the circuit as a two-terminal circuit with a fixed source-impedance, we can use the ac maximum power principle.

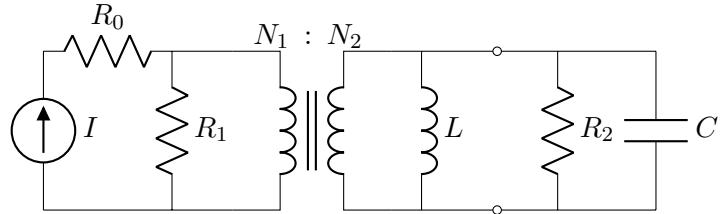

We can omit R_0 , as it is in series with the current source so it doesn't affect what happens in the rest of the circuit.

To simplify handling the transformer, let's remove (bypass) the transformer and scale the components that were on its left, so that they still give the same behaviour between the two nodes that were connected to the transformer's secondary.

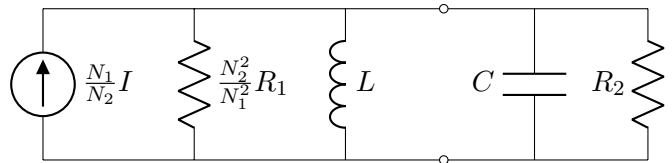

THINKING PHYSICALLY, the procedure for maximum power transfer is first to 'cancel' the source's reactive part with the load's reactive part. The capacitor should be therefore chosen to have the same magnitude of reactance as the inductor, so that these impedances are 'equal and opposite':

$$\frac{1}{j\omega C} = -j\omega L \implies C = \frac{1}{\omega^2 L}.$$

In this parallel case, the result is that the parallel L and C form a parallel-resonant pair, with infinite impedance: their currents always cancel, so they don't affect the rest of the circuit.

Then we're left with just the source and load resistance, for which the maximum power condition can be argued in the same way as in the dc case: load resistance should equal source resistance. Resistor R_2 should therefore be chosen to have the same resistance as the source, when both are seen on the same side of the transformer. From the second diagram above, this means:

$$R_2 = \frac{N_2^2}{N_1^2} R_1.$$

ALTERNATIVELY – thinking more in terms of equations – maximum power transfer requires that the load impedance is the complex conjugate of the source impedance. The same is true for the admittances (reciprocal impedance).

As the circuit is very parallel, it may help to work with admittances. In the parallel connection the separate component admittances add to give the total admittance. This is more convenient than the expressions for parallel impedances, which can make it harder to separate the real and imaginary parts.

$$Y_{\text{source}} = \frac{1}{\frac{N_2^2}{N_1^2} R_1} + \frac{1}{j\omega L}, \quad Y_{\text{load}} = \frac{1}{R_2} + j\omega C, \quad Y_{\text{load}} = Y_{\text{source}}^*, \quad \text{etc.}$$

From this, the same results as before will follow. It is easy because the real and imaginary parts of the admittances are separated *and* do not mix the individual component values, so two independent equations are obtained for finding R_2 and C .

b. Maximum power available is $\frac{1}{4} I^2 R_1$.

This can be seen from just the part to the left of the transformer in the original circuit. R_0 is irrelevant. R_1 limits what power can be delivered from I to the parts further to the right. The transformer doesn't restrict what power flow can happen: it gives no loss or gain of power (although it does change which value of load resistance must be chosen in order to obtain maximum power). The inductor is cancelled when the load's capacitor is chosen for maximum power. So this set of components can deliver whatever maximum power the Norton source of I and R_1 can provide. This is obtained when the load connected to the Norton source is equal to R_1 , in which case the load gets half of the source's current.

An alternative method is to work on the secondary side with scaled quantities.

Ignore L and C , as we know they will together be an open circuit when C is chosen for maximum power.

Then we have a Norton source of $\frac{N_1}{N_2} I$ and $\frac{N_2^2}{N_1^2} R_1$, connected to a load of $R_2 = \frac{N_2^2}{N_1^2} R_1$.

The current in the load is, by current division,

$$i = \frac{N_1}{N_2} I \frac{\frac{N_2^2}{N_1^2} R_1}{\frac{N_2^2}{N_1^2} R_1 + R_2} = \frac{1}{2} \frac{N_1}{N_2} I,$$

so the power in the load is

$$P = i^2 R_2 = i^2 \frac{N_2^2}{N_1^2} R_1 = \left(\frac{1}{2} \frac{N_1}{N_2} I \right)^2 \frac{N_2^2}{N_1^2} R_1 = \frac{1}{4} I^2 R_1.$$

Q9

a. $|u_{2b}| = \frac{N_2}{N_1}U$

Each single-phase source has voltage magnitude U . (By the convention for ‘power’-oriented questions, the magnitude will be rms.) These sources are Y-connected, and the transformer primaries are also Y-connected, so each transformer primary gets voltage magnitude U . The transformer ratio then determines the secondary-voltage magnitudes. u_{2b} is one of these voltages on a transformer secondary.

b. $|i_{R\gamma}| = \frac{N_2U}{N_1\sqrt{3}R}$

The transformer secondaries are Δ -connected, so the line voltage out is the value from part ‘a’. The load resistors are Y-connected, so each gets $1/\sqrt{3}$ of this voltage.

c. $P_{\text{tot}} = \frac{N_2^2U^2}{N_1^2R}$

The total power from the sources is the total power to the resistors, since there is nothing else in the circuit that can absorb or produce active or reactive power.

There are 3 resistors, each with a power $|i|^2R$ where the magnitude $|i|$ is as found in part ‘c’ above.

Thus, $P_{\text{tot}} = 3 \left(\frac{N_2U}{N_1\sqrt{3}R} \right)^2 R = \frac{3N_2^2U^2R}{N_1^2\sqrt{3}^2R^2}$, which simplifies further.

d. $-\frac{2\pi}{3}$, i.e. 120 deg

The load is resistive and balanced. Each phase of the source will therefore provide a current in phase with its voltage.